

## **Installation instructions**

**AUDI Q8 2019 ►**

**AUDI SQ8 2020 ►**

**AUDI RSQ8 2020 ►**

**Swivelling towing bracket  
with electrics set (ECE)**

**for package number 4M8.092.157**

**Audi Genuine Accessories**

Edition 01



## Contents

<b>1</b>	<b>General notes</b> .....	<b>1</b>
<b>2</b>	<b>Safety instructions for pyrotechnical, electrical and mechanical components of the restraint system</b> .....	<b>2</b>
2.1	General safety instructions .....	2
2.2	Storing, transporting and disposing of airbag, belt tensioner and battery disconnecter units (pyrotechnic components) .....	3
<b>3</b>	<b>Safety notes on the towing bracket – mounting and operation</b> .....	<b>4</b>
3.1	Notes on the towing vehicle .....	4
3.2	Notes on the towing bracket .....	4
3.3	Bicycle carrier safety instructions .....	6
3.4	Sensitivity to side winds: safety instructions .....	6
3.5	Notes concerning ECE-R 55 mechanical coupling device guidelines .....	7
<b>4</b>	<b>Overview of components</b> .....	<b>8</b>
4.1	Overview of mechanical components .....	8
4.2	Overview of electrical system components .....	9
4.3	Additional required parts; order separately if necessary: .....	10
<b>5</b>	<b>Assembly overview and tightening torques</b> .....	<b>11</b>
5.1	Towing bracket with cross member .....	11
<b>6</b>	<b>Preparations</b> .....	<b>12</b>
<b>7</b>	<b>Installing the towing bracket</b> .....	<b>14</b>
7.1	Fitting the towing bracket .....	14
7.2	Installing the control unit bracket .....	16
7.3	"Socket/swing motor" retrofit wiring harness routing .....	16
<b>8</b>	<b>Electrical connection</b> .....	<b>17</b>
8.1	Routing the retrofit wiring harness .....	17
8.2	Routing of onboard supply retrofit wiring harness .....	18
8.3	Detaching the relay and fuse holder on the left-hand side of the luggage compartment .....	18
8.4	Release the convenience system central control unit -J393- holder .....	19
8.5	Connecting the retrofit wiring harness CAN bus and brake light signal/terminal 15 to the convenience system central control unit -J393- .....	20
8.5.1	Pin assignment on the convenience system central control unit -J393- .....	20
8.5.2	Integrating the CAN bus .....	20
8.5.3	Connecting the brake light signal/terminal 15 .....	22
8.5.4	Connecting the lighting for the electric swivelling towing bracket release button -E474- terminal 58s .....	24
8.6	Installing the holder and convenience system central control unit -J393- .....	26
8.7	Establishing a power supply .....	26
8.8	Installing the relay and fuse holder on the left-hand side of the luggage compartment .....	28



8.9	Adjusting the electrical connector for load sill lowering button -E539-	29
8.10	Installing the button for the electric swivelling towing bracket -E474-	30
8.11	Creating the opening required for the ball coupling	31
8.12	Reassembling the vehicle	32
<b>9</b>	<b>Concluding operations</b>	<b>33</b>
9.1	Connecting the battery	33
9.2	Activation	33
9.3	Function testing	34
9.4	Finishing the assembly work	34
9.5	Adjusting the cooling system	35





# 1 General notes

Please read and take note of these WARNING, Caution and Note descriptions before carrying out maintenance or repair work.



## **WARNING**

***Text with this symbol contains information concerning your safety and indicates potential accident and injury risks.***



## **Caution**

***Text with this symbol indicates the risk of damage to your vehicle.***



## **Note**

*Text with this symbol contains additional information.*



## **Caution**

***Towing mode places increased demands on the cooling system.***

- ◆ ***The cooling system must be adapted to the vehicle operating conditions ⇒ [Page 35](#).***

**Special tools are required for assembly. Improper installation can cause damage to the vehicle or the add-on parts.**

**Audi AG shall not accept responsibility in the event of failure to comply with these assembly instructions.**



## 2 Safety instructions for pyrotechnical, electrical and mechanical components of the restraint system

### 2.1 General safety instructions

Pyrotechnical components comprise:

- ◆ Airbag units
- ◆ Belt tensioners
- ◆ Belt force limiters
- ◆ Battery disconnecting elements

#### General

- ◆ Testing, installation and maintenance tasks must only be carried out by trained personnel.
- ◆ There are no replacement intervals for airbag units.
- ◆ Do not check using circuit tester, voltmeter, or ohmmeter under any circumstances.
- ◆ Pyrotechnic components must only be checked when installed and using ⇒ vehicle diagnostic testers that have been approved by the manufacturer.
- ◆ When working on pyrotechnic components and the airbag control unit -J234-, the battery earth wire must be disconnected when the IGNITION is SWITCHED ON. The battery negative terminal must subsequently be covered.
- ◆ You must wait ten seconds after the battery -A- has been disconnected.
- ◆ The battery -A- must be connected when the IGNITION is SWITCHED ON. There must not be anybody inside the vehicle during this process. Exception: vehicles with battery -A- located inside the vehicle. Do not sit within the airbag and seat belt deployment range.
- ◆ Observe the appropriate steps after connecting the battery -A- ⇒ [Page 12](#).
- ◆ Before performing any work on pyrotechnic components in the restraint system, e.g. before disconnecting the electrical connector, the mechanic carrying out the task must discharge any static electricity. Electrostatic discharging can be performed by touching earthed metal parts, e.g. by briefly touching the door striker plate.
- ◆ Wash hands after touching ignited pyrotechnical components of the restraint system.
- ◆ Pyrotechnical components must neither be opened nor repaired. New parts must always be used (risk of injury).
- ◆ Pyrotechnic components that have fallen onto a hard surface or that show any sign of damage must not be installed.



- ◆ Pyrotechnic components must be installed immediately after they are removed from the transport container.
- ◆ If work is interrupted, the pyrotechnic component must be returned to the transport container.
- ◆ Pyrotechnic components must not be left unattended.
- ◆ When connecting the pyrotechnic components in the restraint system, only the person performing the work may be inside the vehicle.
- ◆ Pyrotechnic components must not be treated with grease, cleaning agents or similar products.
- ◆ If the fabric becomes contaminated with substances such as oil, grease, paint, colours or solvents, the airbag unit must be replaced.
- ◆ In addition, pyrotechnic components must not be exposed to temperatures above 100°C, even for short periods.

## 2.2 Storing, transporting and disposing of airbag, belt tensioner and battery disconnecter units (pyrotechnic components)

- ◆ Storage is subject to the applicable national legislation.
- ◆ Transportation is subject to national and international laws governing packaging, naming, labelling and accompanying documentation.
- ◆ Pyrotechnic components that have not been ignited must be returned in the original packaging for appropriate recycling in line with the applicable national legislation! Contact your importer if you have any questions.
- ◆ Only pyrotechnic components that have been completely ignited may be disposed of as industrial waste.



### **WARNING**

***This does not apply to belt tensioners that work according to the Wankel tensioner principle. Tensioners of this kind should be handled in the same way as pyrotechnic components that have not been ignited (e.g. airbags).***

***Background: For belt tensioners that work according to the Wankel tensioner principle, it is not possible to use workshop tools to check whether all ignition stages have completed.***



## 3 Safety notes on the towing bracket – mounting and operation

### 3.1 Notes on the towing vehicle

Manufacturer:	Audi AG
Model:	Q8 2019 ►
Offic. Type designation:	4M

Maximum trailer weight or trailer drawbar load in kg, as specified by the manufacturer for the above-named vehicle model: ⇒ Vehicle registration certificate/Owner's Manual.

### 3.2 Notes on the towing bracket

Technical data	
Westfalia:	305 505
ECE no./EU no.:	E13 55R-01 4215
D-value:	16.6 kN
Perm. drawbar load:	140 kg

Please see your vehicle documents for your maximum trailer weight.



#### **WARNING**

***Do not exceed the verified D-value and the permitted trailer drawbar load – risk of accident!***

The towing bracket is intended for towing trailers fitted with a tow ball and for operating carriers suitable for mounting to the coupling ball.

Nationally applicable regulations must be adhered to in EU and non-EU countries.

Improper use is prohibited.

Use is only permitted under favourable road conditions and must be adapted to road conditions.

Refer to the vehicle owner's manual and observe the possibly increased tyre inflation pressures for vehicles with towing brackets or vehicles towing a trailer.

## Assembly



 **WARNING**

**For safety reasons, the towing bracket must only be fitted by skilled personnel – risk of accident!**

- ◆ **If replacement parts are required, these must only be installed by skilled personnel and to undamaged genuine parts – risk of accident!**
- ◆ **Installation must be in line with Audi AG/Volkswagen AG guidelines – risk of accident!**
- ◆ **Modification of the towing bracket is prohibited. This will invalidate the type approval – risk of accident and legal implications!**
- ◆ **Use of the mounting points approved as standard by the vehicle manufacturer is mandatory – risk of accident!**

**Operation**

 **WARNING**

**Vehicle handling is affected by the use of towing mode; increased driver awareness is required – risk of accident!**

- ◆ **Read the notes in the “Towing mode” chapter of the ⇒ Owner’s Manual – risk of accident!**
- ◆ **If you are using trailer stabilisers, the coupling ball must be free from grease. Read and observe the notes in the relevant Owner’s Manuals – risk of accident!**

**The diameter of the ball coupling must be checked at regular intervals.**

- ◆ **For safety reasons, use of the towing bracket must be discontinued if the diameter reaches 49 mm at any point. If this situation occurs, contact a qualified workshop – risk of accident!**

**For safety reasons, you are advised to swivel the ball rod inwards when not in use – risk of accident!**

 **Caution**

**The ball coupling must always be kept clean. Make sure that the rotation sensor on the ball coupling can move freely!**

 **Note**

- ◆ **The towing bracket including all assembly parts weighs approx. 32 kg.**
- ◆ **Please note that the kerb weight of your vehicle will increase by this amount once the towing bracket is fitted.**
- ◆ **Please make sure that you do not exceed the gross vehicle weight rating for your vehicle.**



**i Note**

Use the towing bracket ball coupling to tow trailers.

**⚠ WARNING**

**Do not tow using the eye – risk of breakage!**

**No protective cap must be fitted on the ball head when swivelling in the ball coupling!**

### 3.3 Bicycle carrier safety instructions

**⚠ WARNING**

**The bicycle carrier for the trailer towing coupling is only suitable for transporting bicycles – risk of accident!**

- ◆ **The towing bracket bicycle carrier must only be used to transport bicycles with a total weight of max. 60 kg (132 lbs). When carrying bicycles, the distance from the end of the vehicle to the last bicycle must not exceed 60 cm.**
- ◆ **The bicycle carrier for trailer towing coupling is not suitable for off-road use.**
- ◆ **Do not under any circumstances exceed the maximum load of the bicycle carrier for towing brackets or the drawbar load of the towing bracket.**
- ◆ **The combined weight of the towing bracket bicycle carrier and bicycles must not exceed the gross vehicle weight rating or the gross axle weight rating of the vehicle (⇒ owner's manual).**

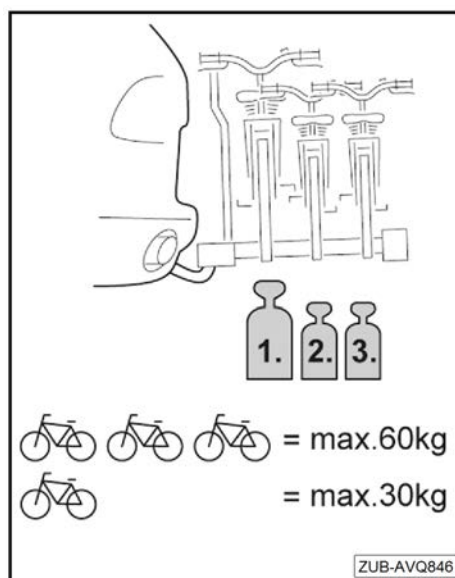

### 3.4 Sensitivity to side winds: safety instructions

**⚠ WARNING**

**The load affects driving and braking behaviour and the vehicle's sensitivity to side winds. Adapt your driving style accordingly – risk of accident!**

**When driving in strong side winds, make sure that you take extra care:**

- ◆ **When moving into and out of the slipstreams of lorries,**
- ◆ **When driving past hedgerows, trees, walls and buildings as well as any other wind barriers,**
- ◆ **When driving over bridges.**



### 3.5 Notes concerning ECE-R 55 mechanical coupling device guidelines

Make sure that clearance is provided in compliance with appendix 7, Figure 25a and 25b of the guideline ECE-R 55.

- 1 - Clearance
- 2 - Vertical plane through the end points of the vehicle's overall length
- 3 - Ground

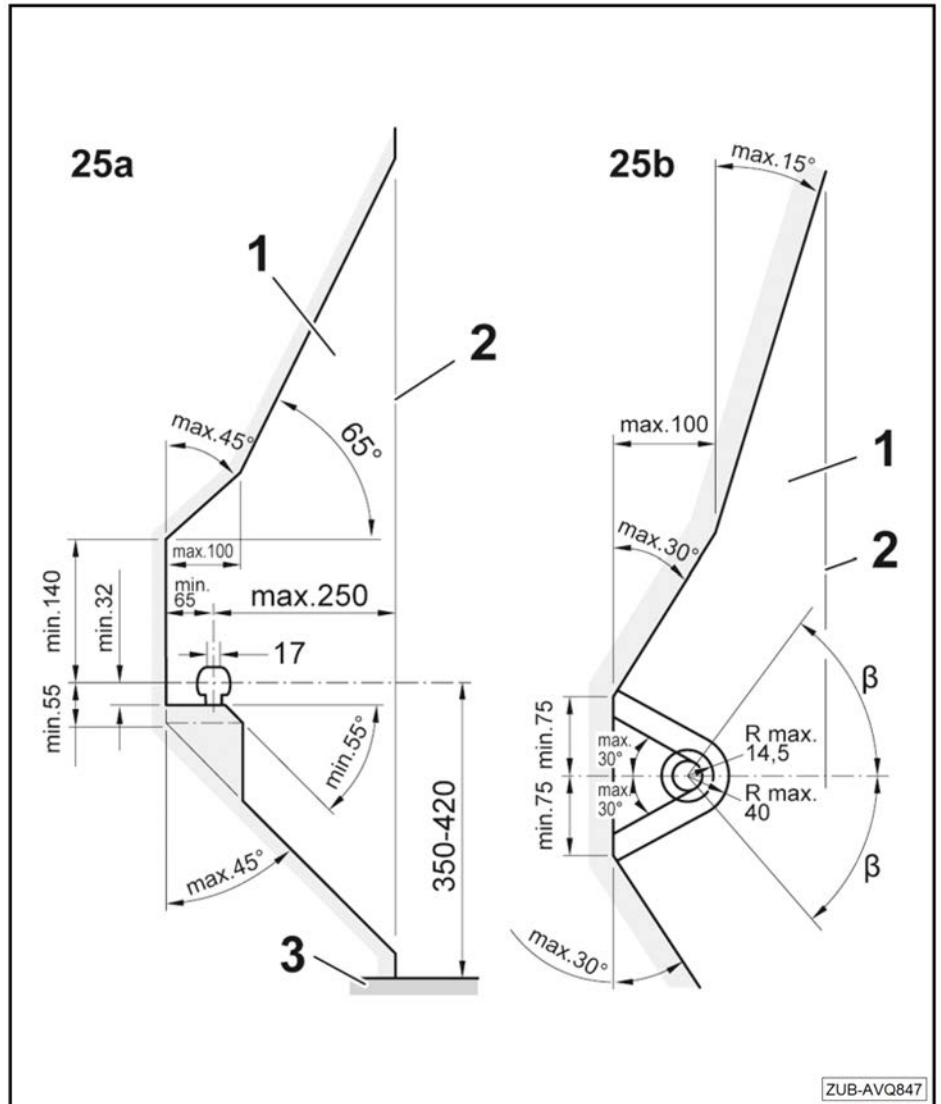

EN



## 4 Overview of components

### 4.1 Overview of mechanical components

#### 1 - Electrical connection

- ❑ "Socket/swing motor" retrofit wiring harness

#### 2 - Towing bracket with electric swivelling cross member including socket/swing motor wiring harness

#### 3 - Foam section

- ❑ Centre
- ❑ Self-adhering

#### 4 - Foam section

- ❑ Right

#### 5 - Screw

- ❑ 8 unit
- ❑ M12x90

#### 6 - Foam section

- ❑ Left

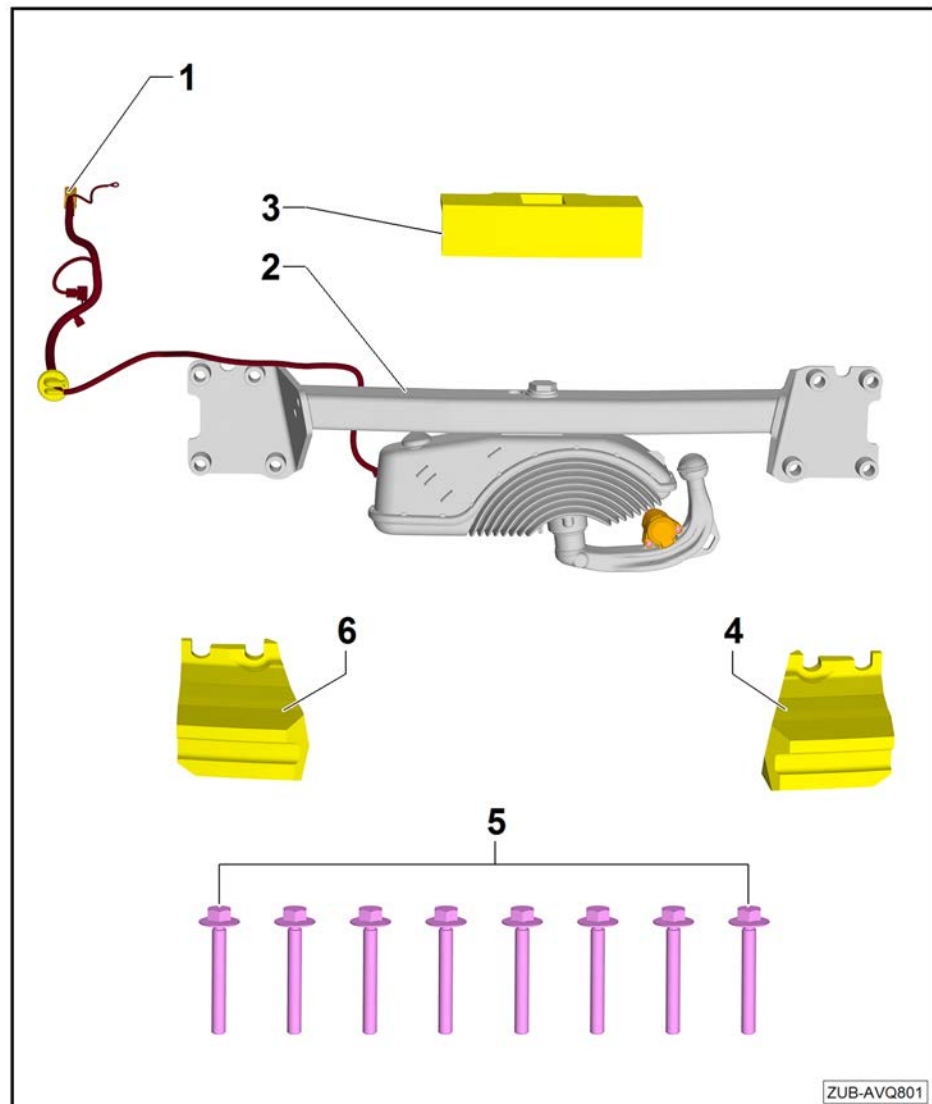



## 4.2 Overview of electrical system components

### 1 - Onboard supply retrofit wiring harness<sup>1)</sup>

- LHD/RHD (swivelling)

### 2 - PE bag

- Attached to the onboard supply wiring harness.

#### Contents

- Socket housing with 3 compartments (black)
- Socket housing with 3 compartments (white)
- Socket housing with 2 compartments (black)

### 3 - Cable ties

- 10x

### 4 - "Towing with towing bracket" sticker

### 5 - Fitting trailer detector control unit -J345-

### 6 - 15 A fuse

- 2 units

### 7 - 25 A fuse

- 2 units

### 8 - 30 A fuse

- 1 units

### 9 - Safety instructions

### 10 - Activation document

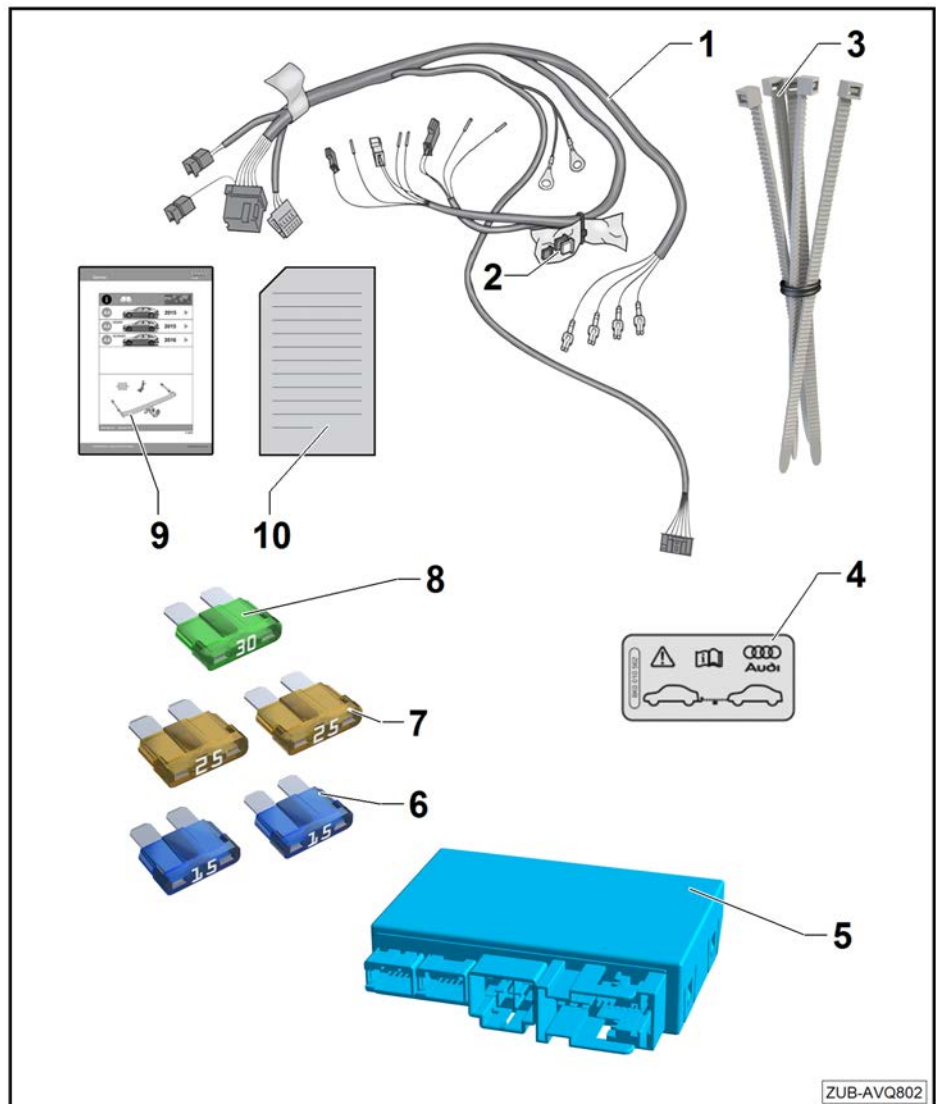

ZUB-AVQ802

1) Not required on vehicles with preparation for towing brackets.



### 4.3 Additional required parts; order separately if necessary:

Holder -1- 4M8.907.297.A ⇒ Electronic parts catalogue ETKA

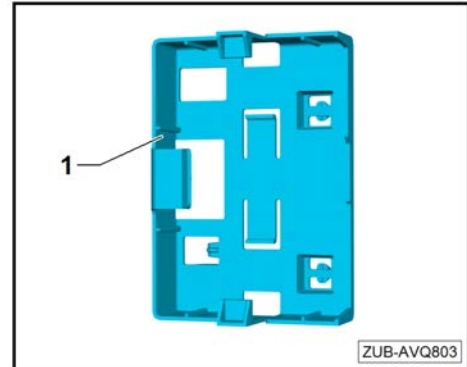

**On vehicles with 1D0/1D8 equipment with load sill lowering, also use as required:**

Button -2- 4M0.959.511.C for electric swivelling towing bracket and load sill lowering ⇒ Electronic parts catalogue ETKA

**Note**

Button mount -1- 4M8.863.365 is already installed.

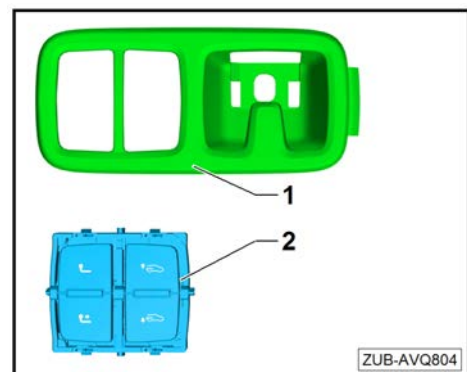

**On vehicles with 1D0/1D8 equipment without load sill lowering, also use as required:**

Button mount -1- 4M8.863.365 ⇒ Electronic parts catalogue ETKA

Electric swivelling towing bracket button -2- 4M0.959.511.D ⇒ Electronic parts catalogue ETKA

Cover strip 4M8.864.123 ⇒ Electronic parts catalogue ETKA

**Additionally required component that is not included in the kit, which must be ordered via ETKA depending on the equipment variant:**

Rear lid power opening sender cable.

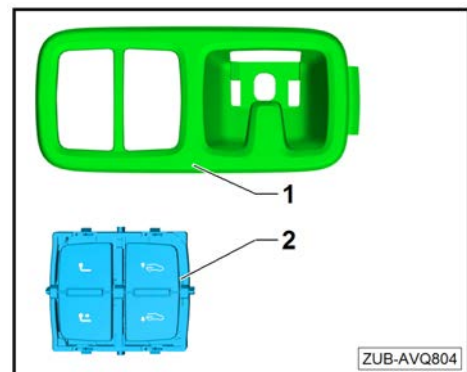



## 5 Assembly overview and tightening torques

### 5.1 Towing bracket with cross member

#### 1 - Electrical connection

- "Socket/swing motor" retrofit wiring harness

#### 2 - Towing bracket with electric swivelling cross member including socket/swing motor wiring harness

#### 3 - Foam section

- Centre
- Self-adhering

#### 4 - Foam section

- Right

#### 5 - Foam section

- Left

#### 6 - Securing bolt

- 8 unit
- M12 x 90
- 110 Nm
- Replace after removal

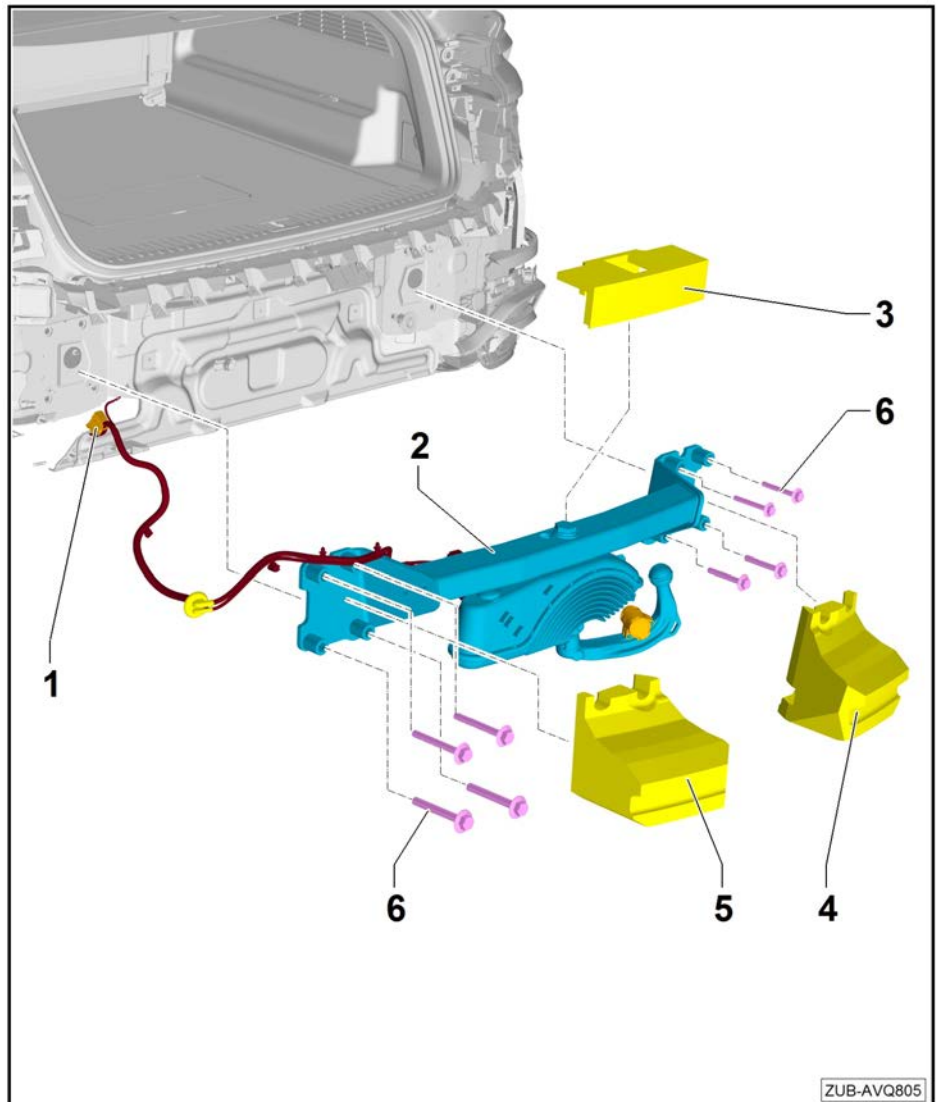



## 6 Preparations

### Required special tools, testing instruments, measuring instruments and auxiliary devices

- ◆ Torque wrench -V.A.G 1410-

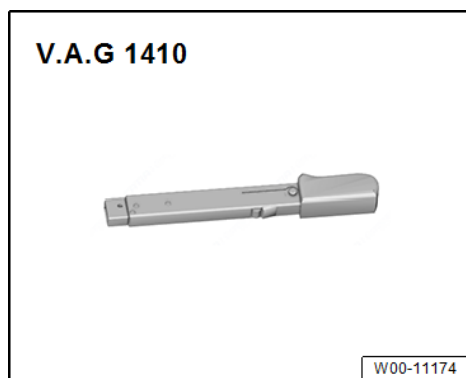

- ◆ Torque wrench -V.A.G 1332-

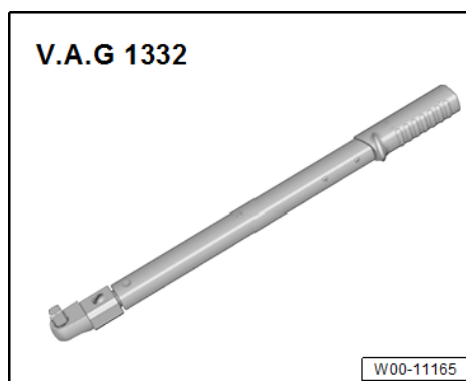

- ◆ Removal lever -80 - 200-

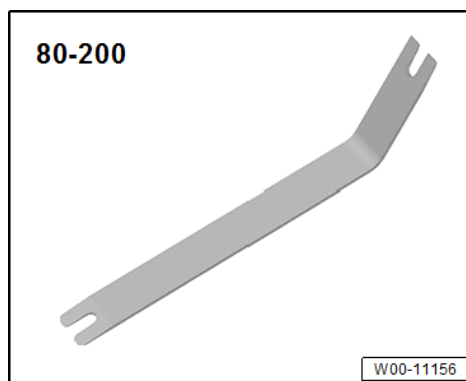

- ◆ Wedge -3409-

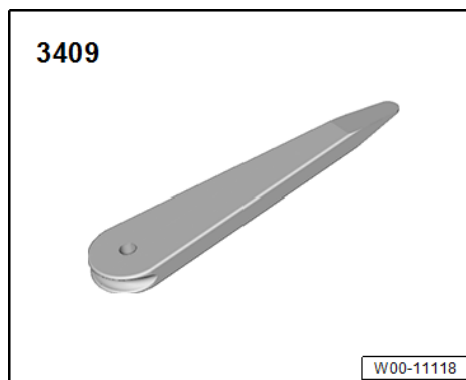



- Disconnect the battery ⇒ Electrical system; Rep. gr. 27; Battery; Disconnecting and connecting the battery
- Remove the rear bumper ⇒ Rear bumper; Rep. gr. 63; Removing and installing the rear bumper
- Remove the rear impact damper ⇒ Rear bumper; Rep. gr. 63; Removing and installing the rear bumper
- Remove the luggage compartment floor ⇒ Trims, insulation; Rep. gr. 70; Removing and installing the luggage compartment floor cover
- Remove the rear cross panel trim ⇒ Trims, insulation; Rep. gr. 70; Removing and installing the rear cross panel trim
- Remove the luggage compartment side trim ⇒ Trims, insulation; Rep. gr. 70; Removing and installing the luggage compartment side trim

**Only on vehicles with digital sound packages**

- Remove the digital sound package control unit ⇒ Communication; Rep. gr. 91; Removing and installing the digital sound package control unit



## 7 Installing the towing bracket

### 7.1 Fitting the towing bracket

#### Preparatory work

##### Note

- ◆ *Foam section -1- is attached to the cross member -2- before assembling the towing bracket and fixed in position using adhesive strips.*
- ◆ *Bonding surfaces must be dry and free of dust and grease.*
- Clean the bonding surface for foam section -1- on the cross member -2-.
- Remove the protective films from the adhesive strips on the foam section -1-.
- Position foam section -1- on the cross member -2- and press down firmly.

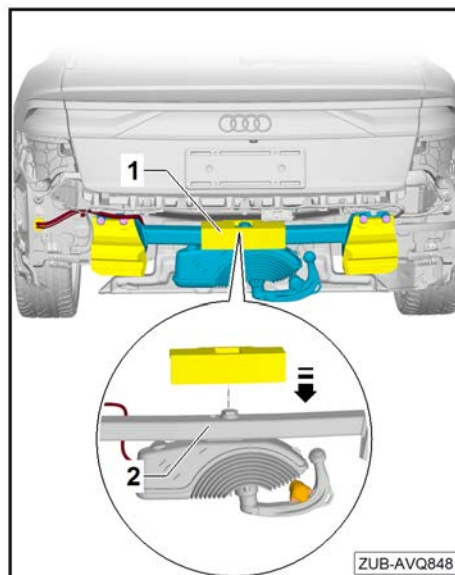

#### Installing the towing bracket

##### Note

- ◆ *When positioning the towing bracket, make sure that the cable -3- is routed over the cross member -1-.*
- ◆ *The contact surface areas between the towing bracket and the vehicle must be cleaned. If necessary, remove drilling chips and treat bare metal body parts with anti-rust paint.*
- Position the cross member -1- on the ends of the frame with the help of a second technician.

##### Caution

***Make sure that the towing bracket with cross member is handled and transported correctly. Only transport the towing bracket on cross member -1-. The ball coupling -2- must not be placed under load in the resting position.***

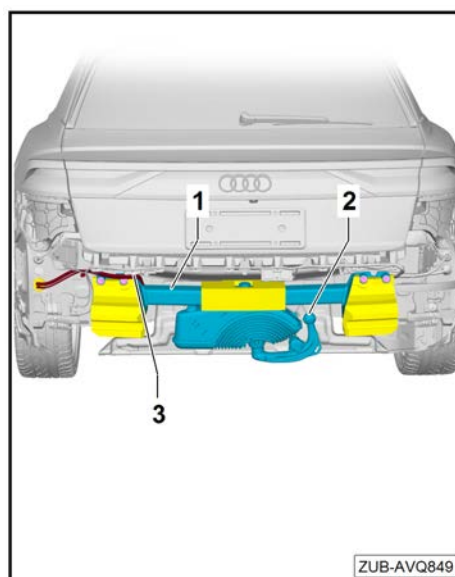



- Insert the left and right bolts -3- for securing the cross member -1- and tighten the bolts by hand.
- Align the towing bracket retaining plate -2- over the bolt holes (centrally) -arrows-.
- Tighten the bolts -3- for towing brackets with cross members  
⇒ Page 11

**⚠ WARNING**

**Securing bolts must only be used once.**

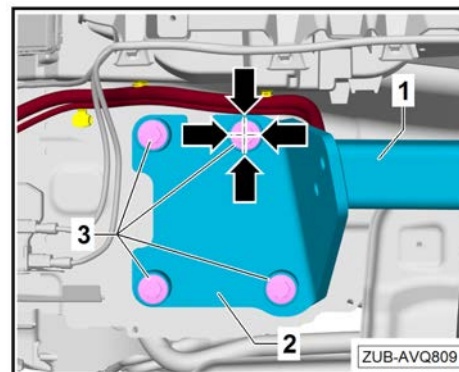

- Remove sealing cap -1- from the opening in the body.

**i Note**

*The cap -1- is no longer required once the towing bracket has been mounted.*

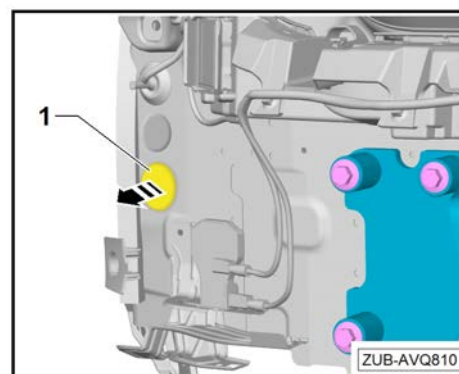

- Guide the "socket/swing motor" retrofit wiring harness through the opening in the body and insert grommet -2-.

**i Note**

*When guiding the wiring through the body, make sure that the electrical connector retaining clip is in the -unlocked- position.*

- Secure the retrofit wiring harness using the retaining clips -1-.

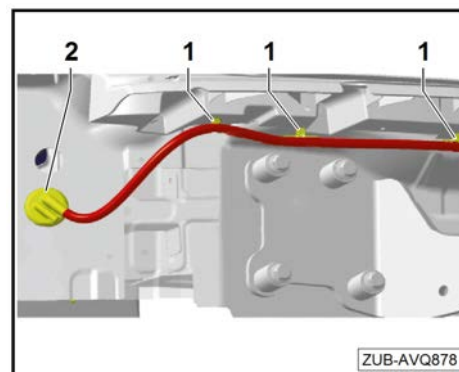

- Clamp the foam sections -1- onto the left-hand and right-hand retaining plates -arrows-.

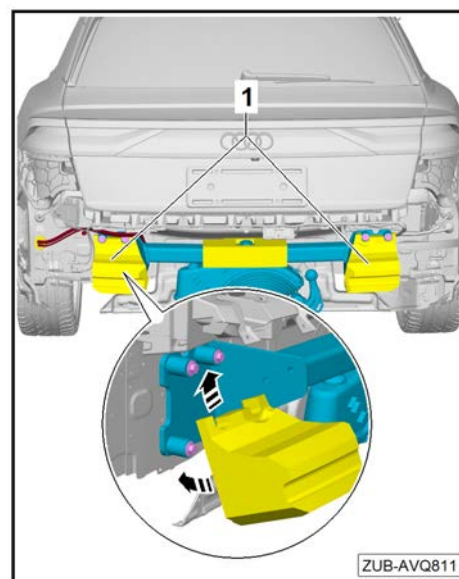



## 7.2 Installing the control unit bracket

Bracket -2- must also be installed in vehicles without a control unit bracket in the left-hand side of the luggage compartment.

Additional required parts:

- Insert the holder -2- into the retaining position -1-.

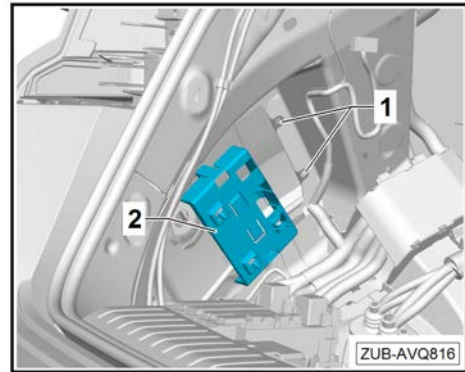

## 7.3 "Socket/swing motor" retrofit wiring harness routing

- Connect electrical connector -1- to the trailer detector control unit -J345- and lock.
- Establish the earth connection for "socket/swing motor" retrofit wiring harness on earth stud -2-.
- Fasten the socket/swing motor retrofit wiring harness -3- to the standard wiring harness using cable ties.

### Note

*The nut on earth stud -2- is only screwed in once the onboard supply retrofit wiring harness has been routed.*

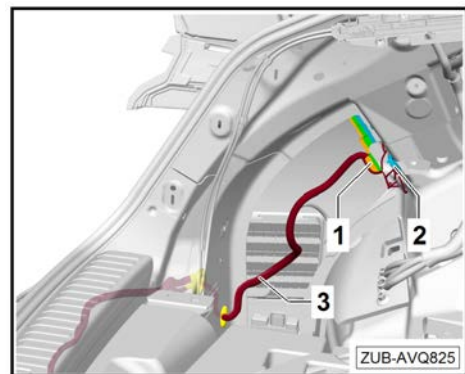

## 8 Electrical connection

### 8.1 Routing the retrofit wiring harness

#### 1 - Fitting trailer detector control unit -J345-

**Note**

Magnified view shows the rear view to depict the exact installation position.

#### 2 - Earth stud

- Luggage compartment, left
- 9 Nm

#### 3 - Routing of onboard supply retrofit wiring harness

#### 4 - Connector for the electric swivelling towing bracket button

#### 5 - Wiring connection, convenience system central control unit -J393-

- CAN bus connection
- Brake light/terminal 15 connection
- Terminal 58s connection

#### 6 - Wiring connection, power supply to fuse carrier

- Fuse 5: 25 A
- Fuse 6: 30 A
- Fuse 7: 15 A
- Fuse 8: 25 A
- Fuse 9: 15 A

#### 7 - Socket/swing motor retrofit wiring harness routing

#### 8 - Control unit holder

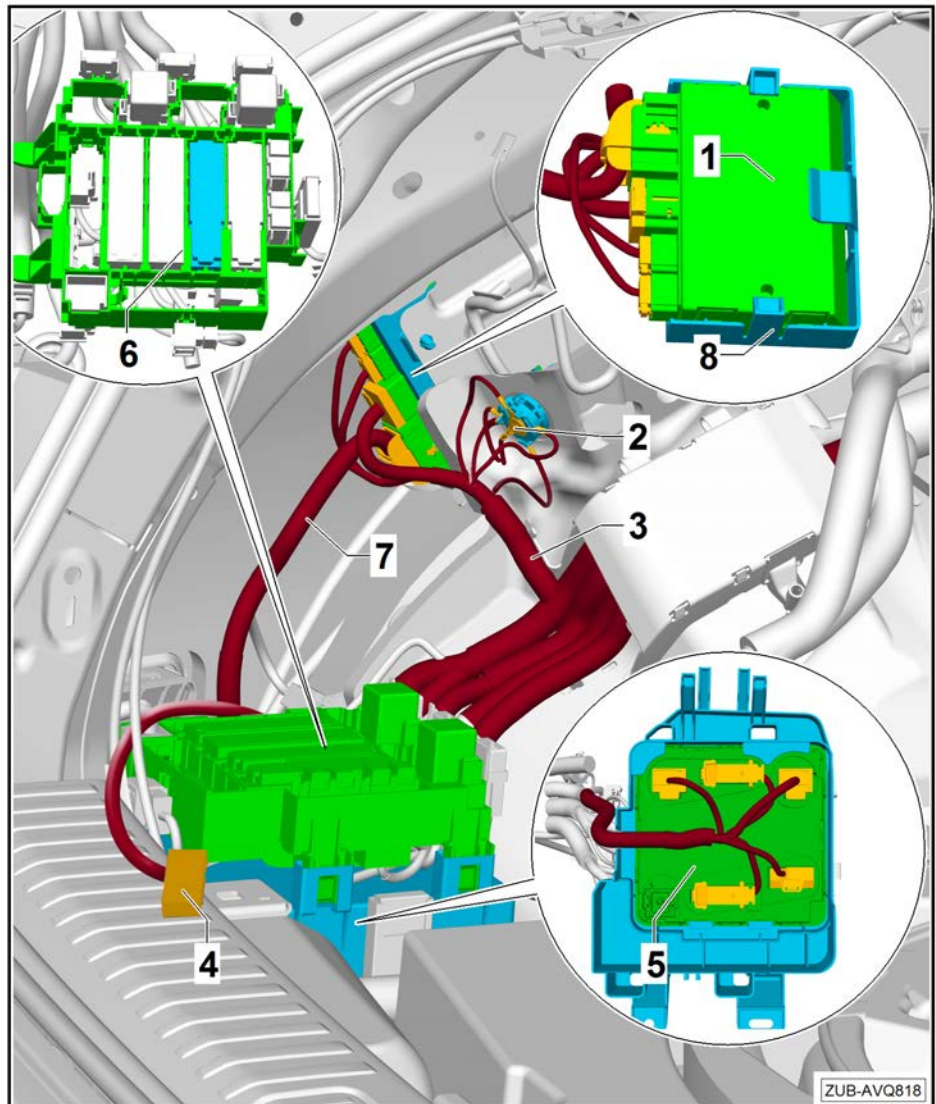



## 8.2 Routing of onboard supply retrofit wiring harness

The onboard supply retrofit wiring harness is only installed on vehicles without preparation for towing brackets.

### Note

*Magnified view shows the rear view to depict the exact installation position.*

- Connect electrical connectors -4, 5 and 6- of the onboard supply retrofit wiring harness -3- to the trailer detector control unit -J345- -1-.
- Route the onboard supply retrofit wiring harness -3- along the vehicle wiring harness and secure.

The wires must be secured with cable ties in a manner that prevents slipping or abrasion.

- Establish the earth connection for the onboard supply retrofit wiring harness on earth stud -2-.
- Tighten the nut on earth stud -2- to create an earth connection for the "socket/swing motor" retrofit wiring harness and the onboard supply with tightening torque ⇒ [Page 17](#).

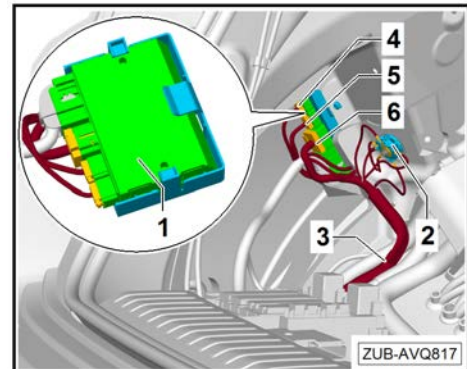

## 8.3 Detaching the relay and fuse holder on the left-hand side of the luggage compartment

- Unlock retaining clips -3- and slightly detach the relay and fuse holder -1-.
- Pull the relay and fuse holder -1- from the guides -2- and put them to one side. The electrical wiring remains connected.

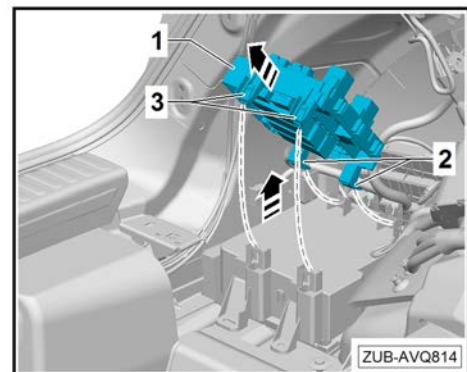



## 8.4 Release the convenience system central control unit -J393- holder

- Loosen and remove securing nuts -3-.
- Remove the holder -1- together with the convenience system central control unit -J393- -4- upwards out of the guides -2-.
- Put the convenience system central control unit -J393- -4- and holder -1- to one side. The electrical wiring remains connected.

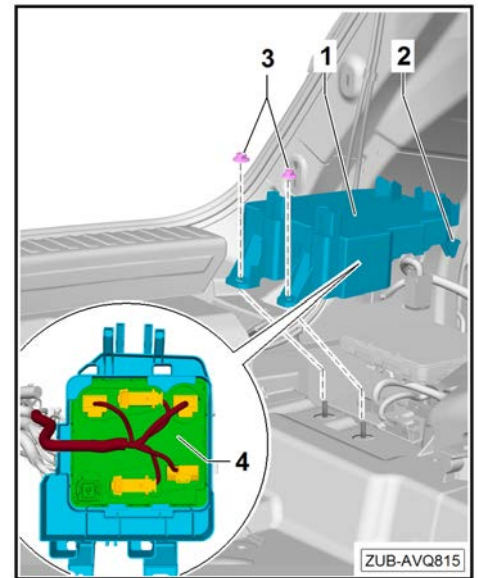



## 8.5 Connecting the retrofit wiring harness CAN bus and brake light signal/terminal 15 to the convenience system central control unit -J393-

### 8.5.1 Pin assignment on the convenience system central control unit -J393-

1 - Convenience system central control unit -J393-

A - 17-pin connector, brown

B - 32-pin connector, black

C - 17-pin connector, black

D - 20-pin connector, black

E - 32-pin connector, blue

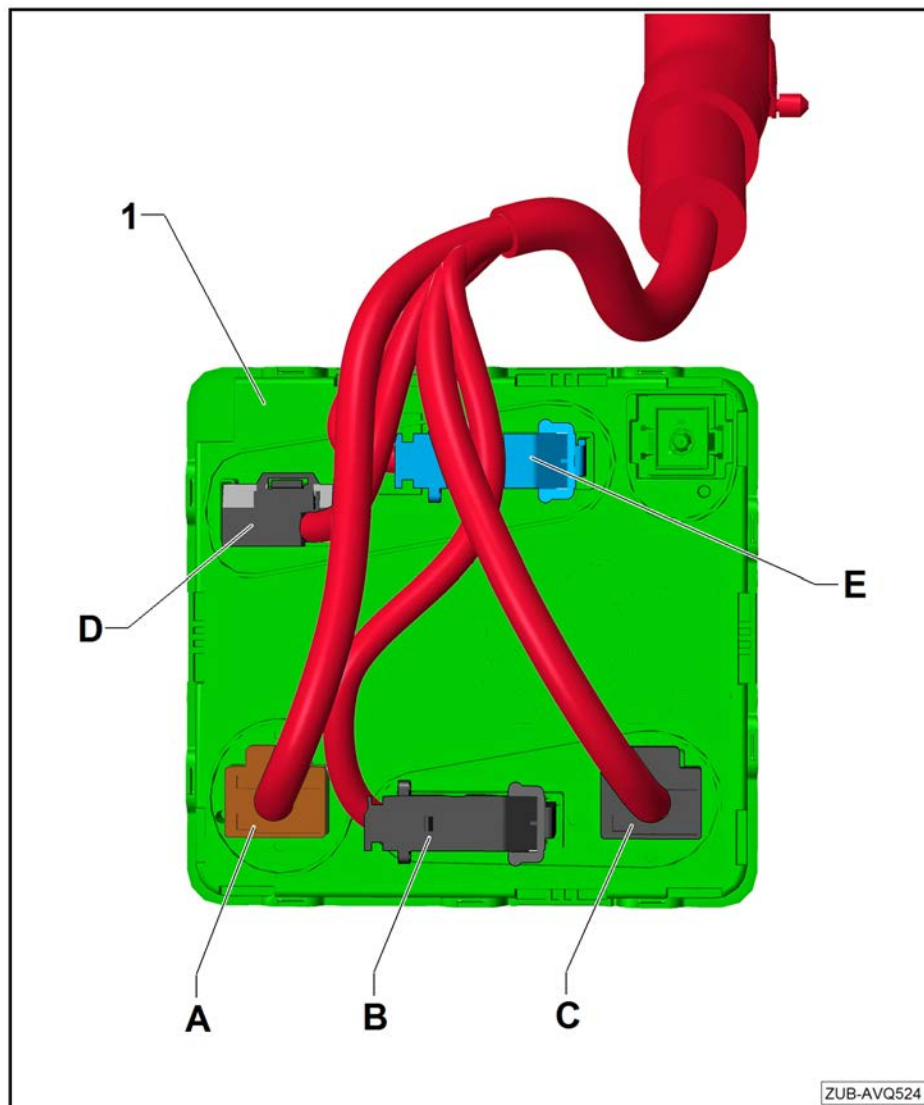

### 8.5.2 Integrating the CAN bus

- Release the blue connector -E- from the convenience system central control unit -J393- and disconnect.

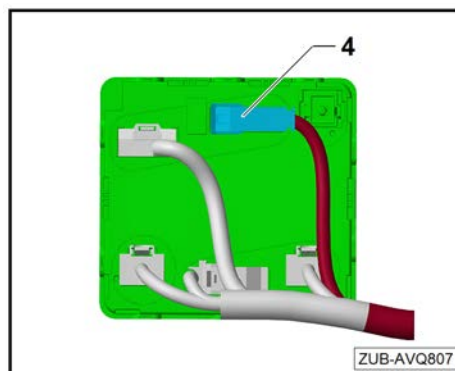



EN

- Release the catches on the blue connector housing -arrows- and pull the connector block out of the connector housing.

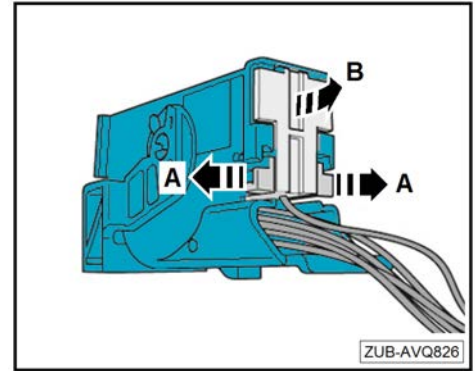

- Find the pin assignment -1, 16, 17 and 32- on the connector block and write on the block using a waterproof pen to make these easier to locate.
- Unpin contact from compartment -1- of the connector block.
- Unpin contact from compartment -2- of the connector block.

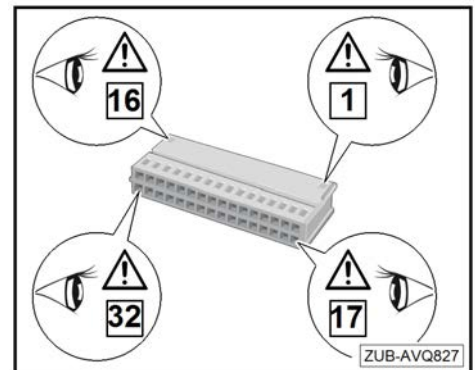

- Pin contact 1 of the connector block into compartment -1- of the included black socket housing -A- (3 chambers). (Rear view)
- Pin contact 2 of the connector block into compartment -3- of the included black socket housing -A- (3 chambers). (Rear view)

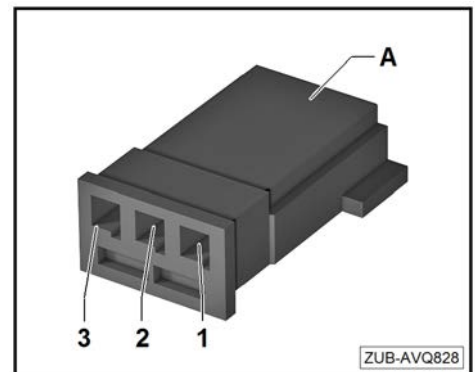

- Pin the corresponding contacts of the onboard supply retrofit wiring harness (Y-wires) into the compartments on the connector block.
- Pin the -orange/brown- wire of the retrofit wiring harness into compartment -1- of the connector block (CAN bus Low).
- Pin the -orange/green- wire of the retrofit wiring harness into compartment -2- of the connector block (CAN bus High).
- Insert the connector block into the blue connector housing and click into place.

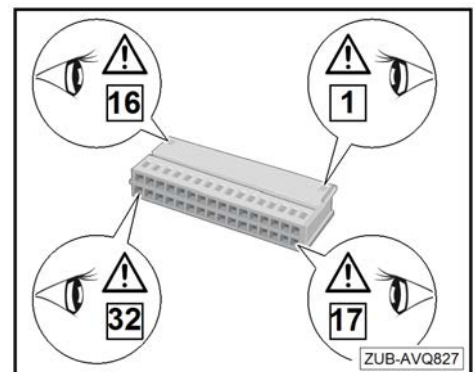



- Connect the socket housing (black) with the corresponding black connector on the onboard supply retrofit wiring harness -arrow-.
- Connect the blue connector to the convenience system central control unit -J393- and lock.

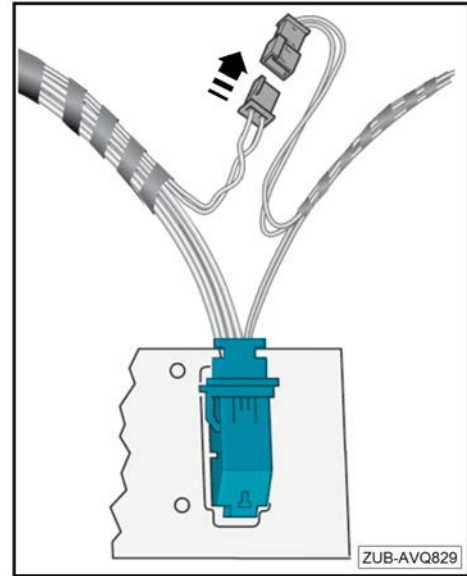

### 8.5.3 Connecting the brake light signal/terminal 15

- Release and disconnect the black, 32-pin connector -B- from the convenience system central control unit -J393-.

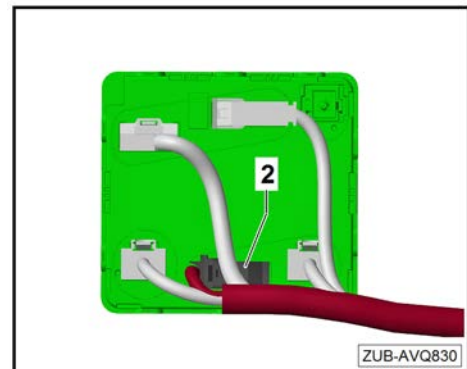

- Release the catches on the black connector housing -arrows- and pull the connector block out of the connector housing.

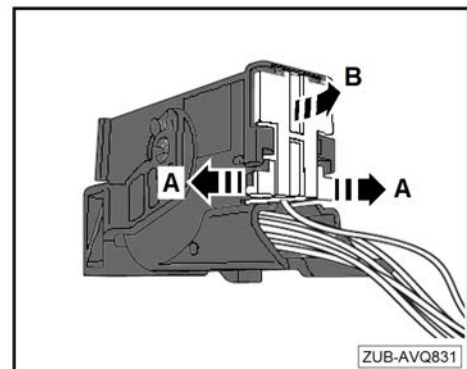



- Find the pin assignment -1, 16, 17 and 32- on the connector block and write on the block using a waterproof pen to make these easier to locate.
- Unpin contact from compartment -12- of the connector block.
- Unpin contact from compartment -17- of the connector block.

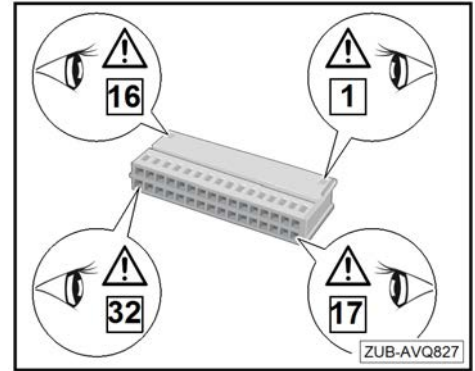

- Pin contact 12 of the connector block into compartment -3- of the included white socket housing -A- (3 chambers). (Rear view)
- Pin contact 17 of the connector block into compartment -1- of the included white socket housing -A- (3 chambers). (Rear view)

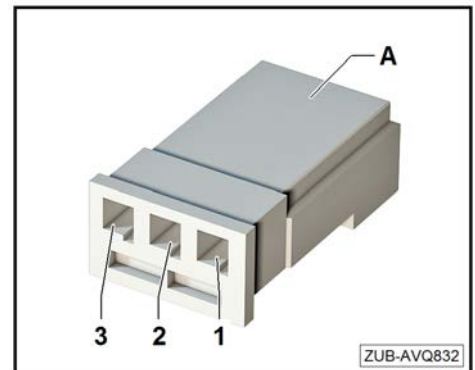

- Pin the corresponding contacts of the onboard supply retrofit wiring harness (Y-wires) into the compartments on the connector block.
- Pin the -black/red- wire of the retrofit wiring harness into compartment -12- of the connector block.
- Pin the -black- wire of the retrofit wiring harness into compartment -17- of the connector block.
- Insert the connector block into the black connector housing and click into place.

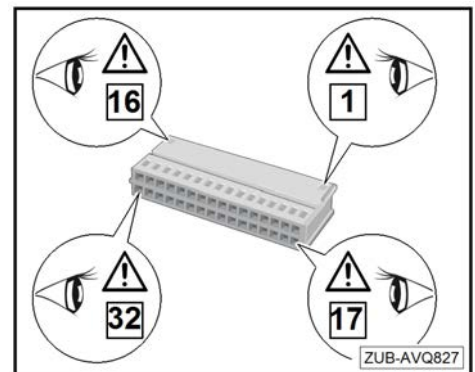

- Connect the socket housing (white) with the corresponding white connector on the onboard supply retrofit wiring harness -arrow-.
- Connect the black connector to the convenience system central control unit -J393- and lock.

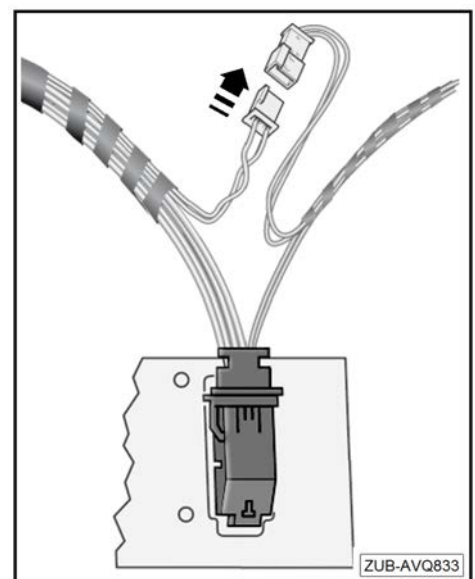



### 8.5.4 Connecting the lighting for the electric swivelling towing bracket release button -E474- terminal 58s

- Release the brown connector -A- from the convenience system central control unit -J393- and disconnect.

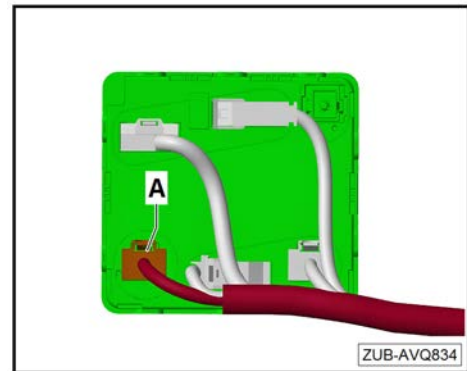

- Unlock the housing retaining clip on the brown connector housing and pull out -arrows-.

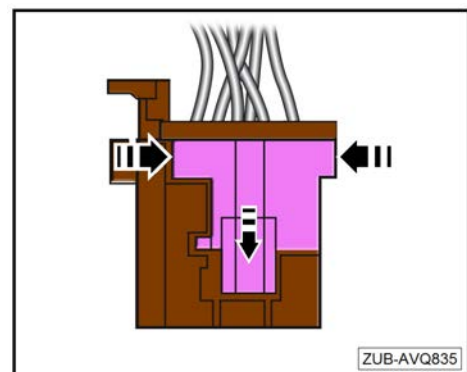

- Unpin contact from compartment -5- of the connector.

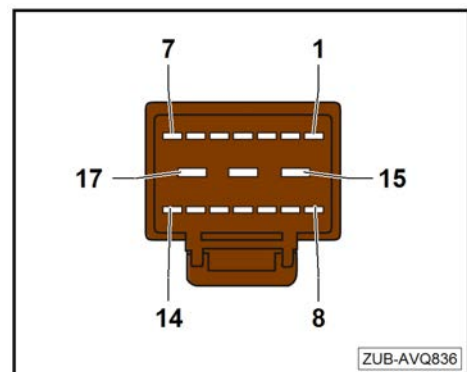

- Pin contact 5 of the connector block into compartment -1- of the included black socket housing -A- (2 chambers).

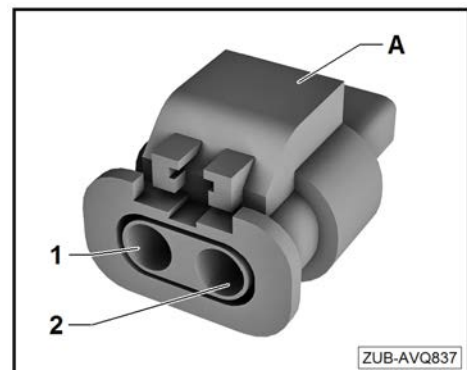



- Pin the corresponding contact of the onboard supply retrofit wiring harness (Y-wires) into the compartment of the connector housing.
- Pin the -yellow/black- wire of the retrofit wiring harness into compartment -5-.
- Push the housing retaining clip into the brown connector housing and lock.
- Insert the connector block into the black connector housing and lock.

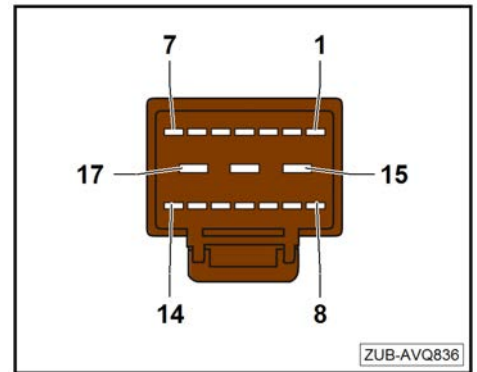

- Connect the socket housing (black, 2 compartments) with the corresponding black connector (2 compartments) on the onboard supply retrofit wiring harness -arrow-.
- Connect the brown connector to the convenience system central control unit -J393- and lock.

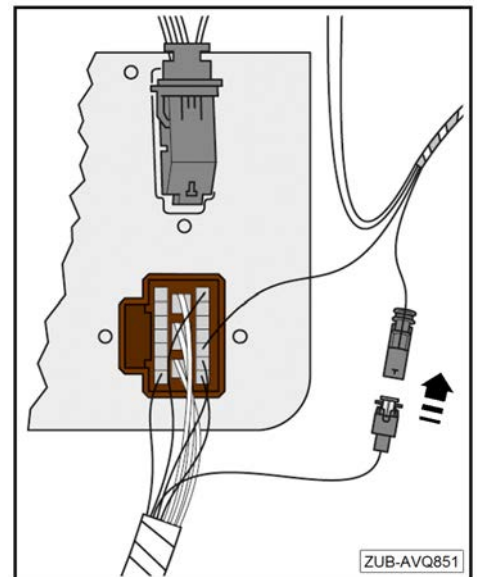

- Secure the onboard supply retrofit wiring harness to the vehicle's wiring harness using cable ties.
- The wires must be secured with cable ties in a manner that prevents slipping or abrasion.

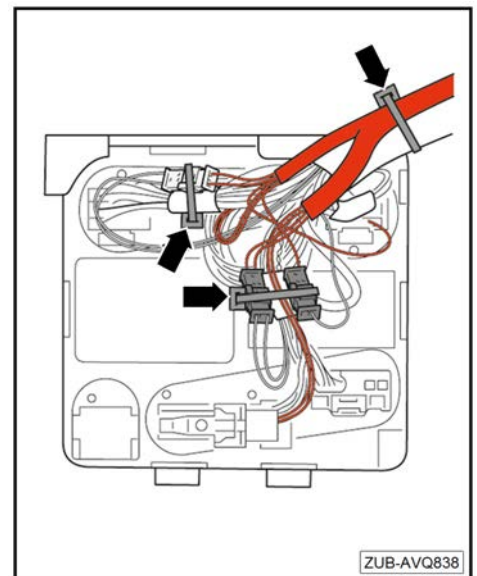

EN



## 8.6 Installing the holder and convenience system central control unit -J393-

- Clip the convenience system central control unit -J393- -4- back into the holder -1-.
- Insert holder -1- along with the convenience system central control unit -J393- into the guides -2-.

### Note

Route electrical wiring in such a way that the original wiring routing is restored.

- Position and tighten securing nuts -3-.
- Tightening torque for the securing nuts -3- is 3 Nm.

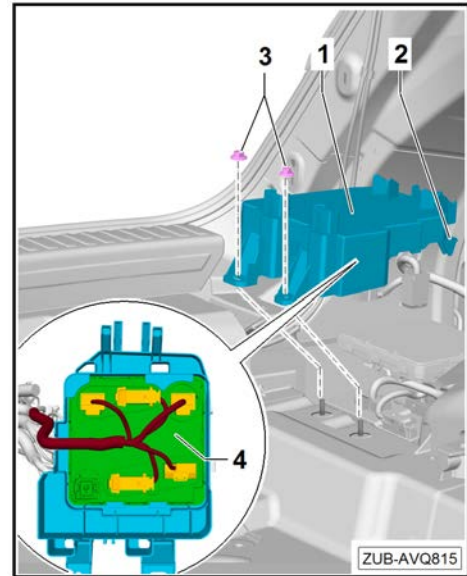

## 8.7 Establishing a power supply

- Release the retaining tab -arrow- and remove the fuse carrier from position -2- of the relay and fuse holder -1- in a downwards direction.

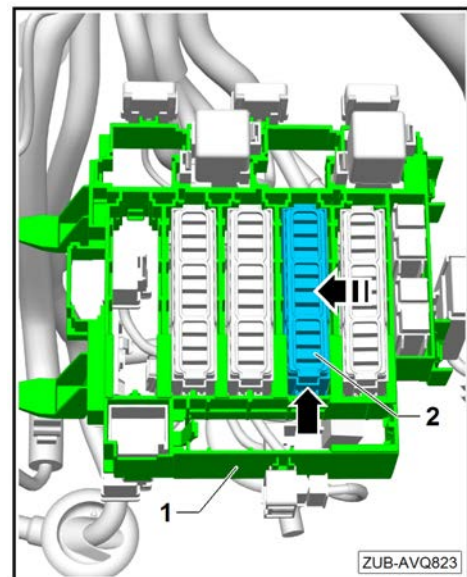

- Release the retaining clips -in the direction of the arrow- and remove the cover from the fuse carrier.

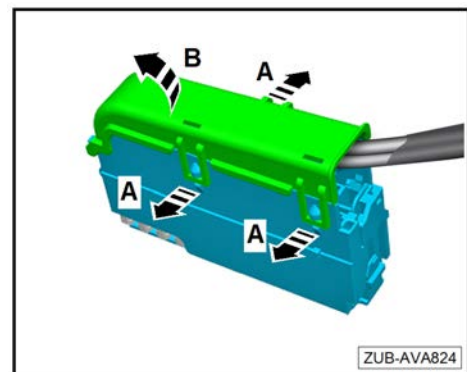



- Pull out the retaining strip -1- for the electrical connectors -in the direction of the arrow-.

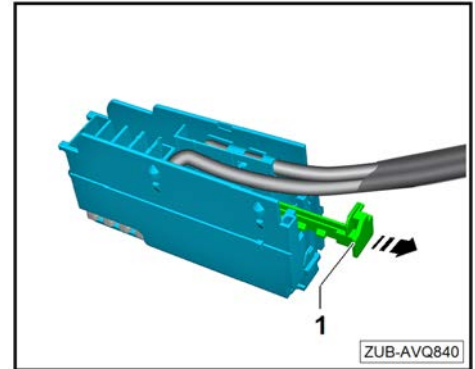

- Unlock the retainer from the fuse carrier -arrows- and remove -in the direction of the arrow-.

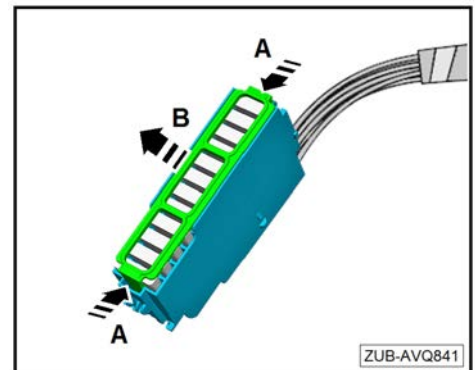

- Plug the onboard supply retrofit wiring harness contacts into fuse positions -5 to 9- on the fuse carrier.

- ◆ Compartment 9a: red wire
- ◆ Compartment 8a: red/blue wire
- ◆ Compartment 7a: red/green wire
- ◆ Compartment 6a: red/yellow wire
- ◆ Compartment 5a: red/black wire

- Insert the electrical connector retaining strip.

- Connect fuses 5, 6, 7, 8 and 9.

- ◆ Fuse 9: 15 A
- ◆ Fuse 8: 25 A
- ◆ Fuse 7: 15 A
- ◆ Fuse 6: 30 A
- ◆ Fuse 5: 25 A

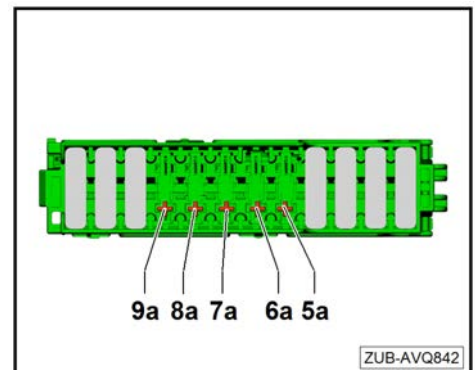



- Install the retainer on the fuse carrier and lock.
- Install the cover for the fuse carrier and lock.
- Insert the fuse carrier into position -2- of the relay and fuse holder -1- and click into place.

**Note**

Route electrical wiring in such a way that the original wiring routing is restored.

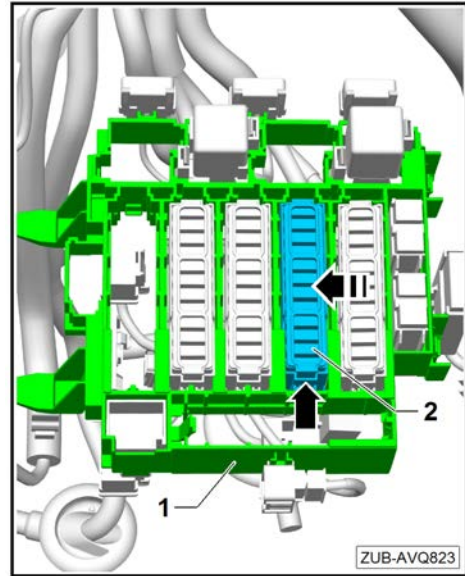

- Secure the onboard supply retrofit wiring harness to the vehicle's wiring harness using cable ties -arrow-.
- The wires must be secured with cable ties in a manner that prevents slipping or abrasion.

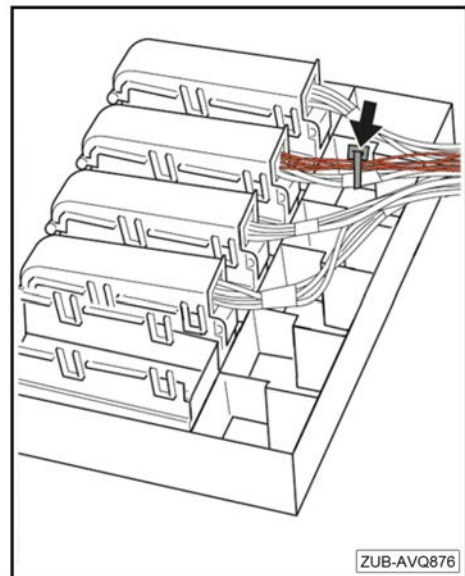

## 8.8 Installing the relay and fuse holder on the left-hand side of the luggage compartment

Installation is carried out in reverse order. Please note the following points:

- Route electrical wiring in such a way that the original wiring routing is restored.

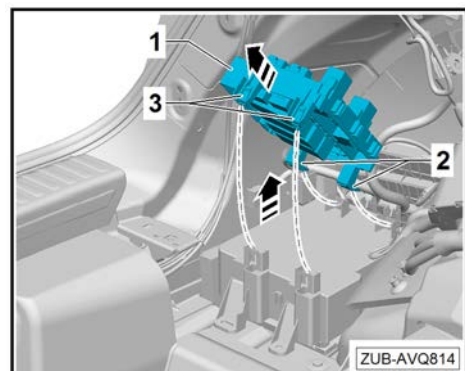



## 8.9 Adjusting the electrical connector for load sill lowering button -E539-

### Only applies to vehicles with load sill lowering

Unpin contacts 7, 8, 10, 11 and 12 from the electrical connector for the electric swivelling towing bracket button -E474-. Next, pin the contacts into the respective compartments of the electrical connector for the load sill lowering button -E539-.

- Release the catch -1- of the electrical connector for the load sill lowering button -E539- on the vehicle wiring harness and pull out the housing retaining clip -2- to the side -arrow-.
- Release the catch -1- of the electrical connector for the electric swivelling towing bracket button -E474- on the onboard supply retrofit wiring harness and pull out the housing retaining clip -2- to the side -arrow-.

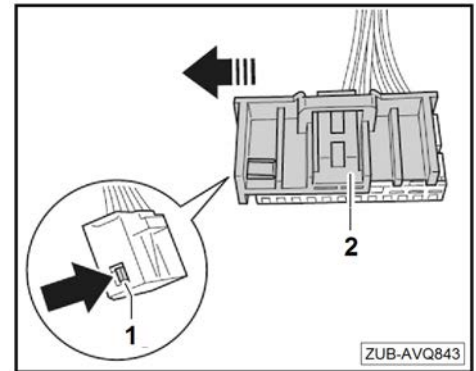

- Unpin the contacts from compartments 7, 8, 10, 11 and 12 of the connector housing -1- electric swivelling towing bracket button -E474- on the onboard supply retrofit wiring harness.
- Pin the unpinned contacts into the respective compartments of the connector housing -2- load sill lowering button -E539- on the vehicle's wiring harness.

- ◆ Compartment 7: yellow/green wire
- ◆ Compartment 8: grey wire
- ◆ Compartment 10: yellow/white wire
- ◆ Compartment 11: yellow/brown wire
- ◆ Compartment 12: yellow/blue wire

#### Note

The contact in compartment 6 of the connector housing for the electric swivelling towing bracket button -E474- remains pinned in place.

- Insert the housing retaining clip on the connector housing of the electric swivelling towing bracket button -E474- and engage.
- Insert the housing retaining clip on the connector housing of the load sill lowering button -E539- and engage.

#### Note

Electrical connector -2- is no longer required.

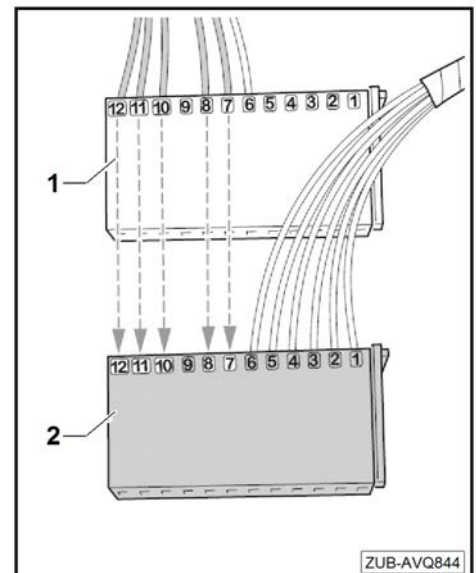



- Wrap the electrical connector -2- for the electric swivelling towing bracket button -E474- with fabric tape -1- to the vehicle's wiring harness for the electrical connector -3- load sill lowering button -E539- and fix in position.

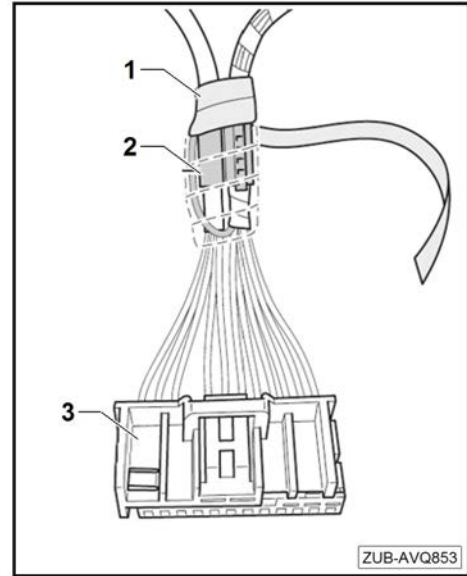

## 8.10 Installing the button for the electric swivelling towing bracket -E474-

### Note

- ◆ Depending on your equipment variant, the electric swivelling towing bracket button must be replaced.

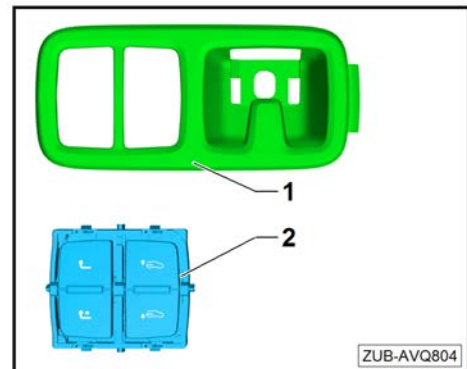

- Plug in the electrical connector -3- on button -2-.
- Insert the frame -1- in the side trim and clip in button -2- until it audibly engages.
- When installing the luggage compartment side trim, route electrical wiring in a manner that prevents the wires from being abraded or trapped.

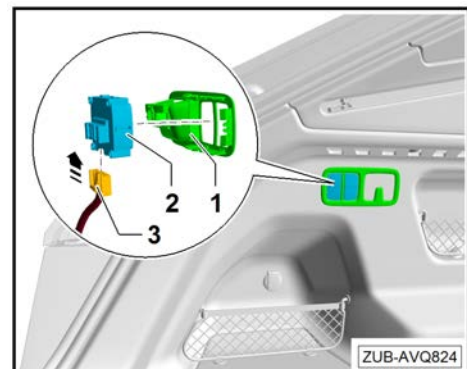

## 8.11 Creating the opening required for the ball coupling

### Applies only to vehicles without the rear lid power opening sender cable

- Cut out the bumper cover diffuser -2- along the pre-defined marking -1- using a suitable tool.
- Carefully deburr the cut edges.

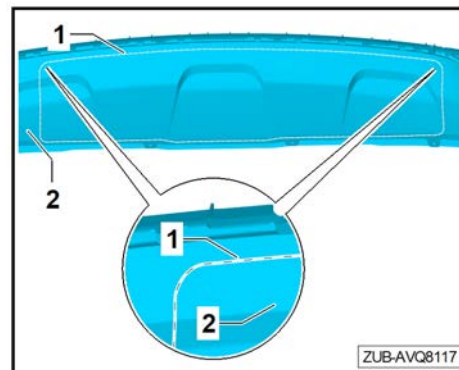

### Applies only to vehicles with the rear lid power opening sender cable

#### Diffuser adaption without towing bracket opening on vehicles equipped with rear lid power opening sender cable in the rear bumper

- Remove the rear lid power opening control unit and sender cable.
- Cut out the rear bumper cover diffuser along the marking -2- flush with the frame -1- for the rear lid power opening sender using a suitable tool.
- Carefully deburr the cut edges.

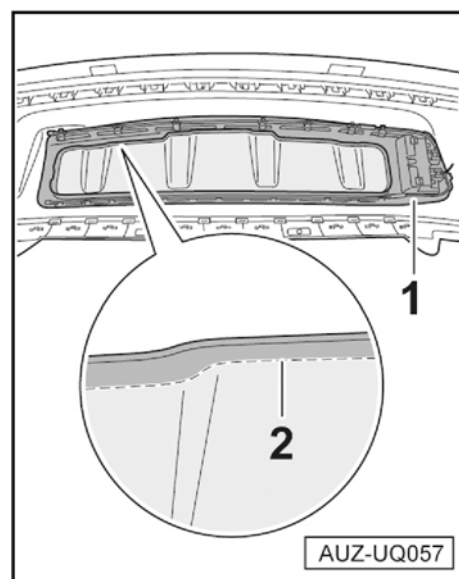

- Install the rear lid power opening control unit -2-.

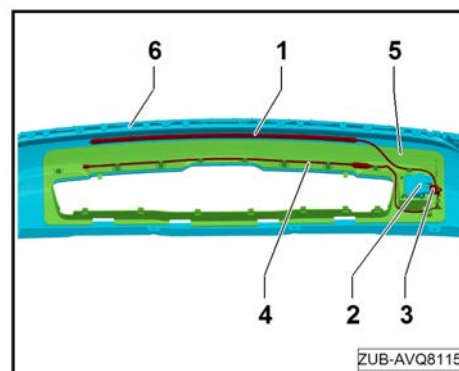



- Install the rear lid power opening sender cable -3- with the two individual aeri-als -1 and 4-. See ETKA!

**⚠ WARNING**

*The connector for the rear lid power opening sender -3- is plugged into position -B- on control unit -2-, with the locating element ensuring the correct orientation.*

*The two aerial wires -1 and 4- cross over at the connector -3- magnifying glass-. Note the correct installation position and routing!*

*The upper connector outlet belongs to the individual aerial -4-. This must be routed over the opening in the holder -5-.*

*The lower connector outlet belongs to the individual aerial -1-. This must be routed above the bracket -5- in the upper area of the bumper.*

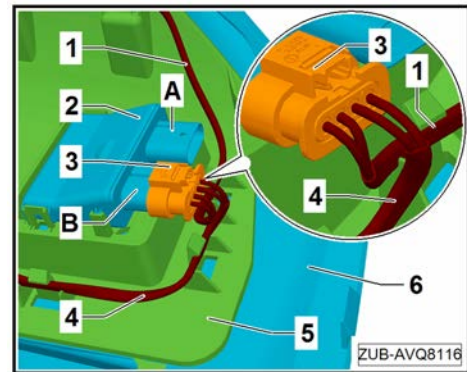

- Connect the rear lid power opening control unit to the on-board supply connector -2- via position -A-.

## 8.12 Reassembling the vehicle

The vehicle is assembled in the reverse order. Read and observe the notes on installation for the relevant components and the corresponding tightening torques.

On vehicles with lane change assist, this must be recalibrated.

**⚠ WARNING**

*The following information must be observed when working with the lane change assist (Audi side assist):*

- ◆ *If the rear bumper cover is removed and then reinstalled, or if any modifications are made to the rear bumper cover, the lane change assist system (Audi side assist) must be recalibrated ⇒Electrical system; Rep. gr. 96; Risk of accident due to malfunction!*

*With regard to vehicles fitted with a rear view camera, observe the following:*

- ◆ *If the rear bumper cover is removed and then reinstalled, or if any modifications are made to the rear bumper cover, the rear view camera system must be calibrated ⇒Electrical system; Rep. gr. 91; Calibrate the rear view camera system!*



## 9 Concluding operations

### 9.1 Connecting the battery

- Workshop Manual ⇒ Electrical system; Rep. gr. 27; Disconnecting and connecting the battery

 **Note**

*After reconnecting the power supply, the ESP warning light can only extinguish after a few metres have been driven.*

### 9.2 Activation

- ◆ It must be guaranteed that the open-circuit voltage of the vehicle battery is at least 12.5 Volts. To maintain the vehicle voltage during the process, connect a battery charger -VAS 590X-.
- ◆ If the procedure and test operation is completed without errors, the vehicle configuration is only performed once. Unless prompted, multiple attempts to configure the vehicle can cause error messages and have no impact on the configuration.
- ◆ The FM code (activation code), the license number (activation number) and the PIN (activation PIN) are required to update the software. This information can be found in the enclosed software certificate.
- Connect the vehicle diagnostic tester with ODIS service to the diagnostic connection on the vehicle when the ignition is switched off.
- Switch on ignition.
- Select the "Start diagnosis" (Diagnose starten) operating mode and identify the vehicle.
- Switch to the "Control units" (Steuergeräte) tab and call up the "Event memory list" (Ereignisspeicherliste) to obtain an overview of all stored entries in the event memory.
- Rectify any relevant faults and clear the event memory.
- Switch to the "Special functions" (Sonderfunktionen) tab and select "Software Version Management (SVM)".
- Start "SVM - Enable" (SVM - Freischaltung) and observe notes and test conditions!
- Select "-1- Enable newly acquired data/functions" (-1- neu erworbene Daten/Funktionen freischalten) and follow the instructions given by the vehicle diagnostic tester.

After the code is entered, the online connection is established and the software adaptation is carried out.

- End diagnosis.
- Switch off the ignition and disconnect the vehicle diagnostic tester.



**⚠ WARNING**

**The following information must be observed when working with the lane change assist (Audi side assist):**

- ◆ **If the rear bumper cover is removed and then reinstalled, or if any modifications are made to the rear bumper cover, the lane change assist system (Audi side assist) must be recalibrated ⇒Electrical system; Rep. gr. 96; Risk of accident due to malfunction!**

**With regard to vehicles fitted with a rear view camera, observe the following:**

- ◆ **If the rear bumper cover is removed and then reinstalled, or if any modifications are made to the rear bumper cover, the rear view camera system must be calibrated ⇒Electrical system; Rep. gr. 91; Calibrate the rear view camera system!**

### 9.3 Function testing

#### Pin assignment in the trailer socket -U10-

- 1 - Terminal LTS (left turn signal)
- 2 - Terminal RFL (rear fog light)
- 3 - Terminal 31 (earth) earth for terminals 1–2, 4–8
- 4 - Terminal RTS (right turn signal)
- 5 - Terminal 58 R (right tail light)
- 6 - Terminal 54 (brake light)
- 7 - Terminal 58 L (left tail light)
- 8 - Terminal RVL (reversing light)
- 9 - Terminal 30 (battery "+ ") max. current 15 A
- 10 - Terminal 15 (charging cable) max. current 15 A
- 11 - Terminal 31 (earth) earth for terminal 10
- 12 - Not assigned
- 13 - Terminal 31 (earth) earth for terminal 9

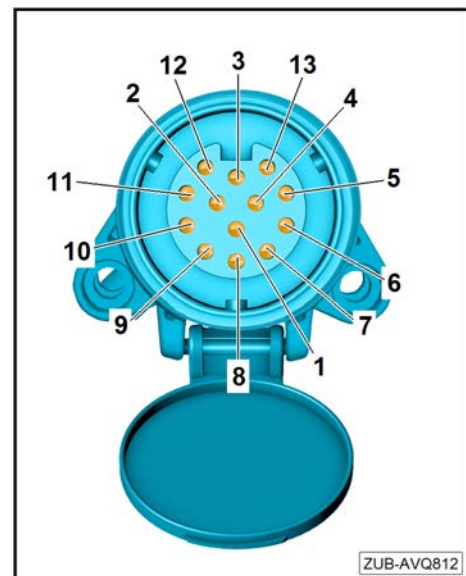

### 9.4 Finishing the assembly work

- Clean the bonding surfaces and affix the “Towing with towing bracket” sticker to the inner left of the D-pillar.

**i Note**

**Bonding surfaces must be dry and free of dust and grease!**

- Once assembled, check the towing bracket functions correctly ⇒ Owner's Manual.
- Keep these assembly instructions with the vehicle documents so that they can be presented to authorised persons upon request.

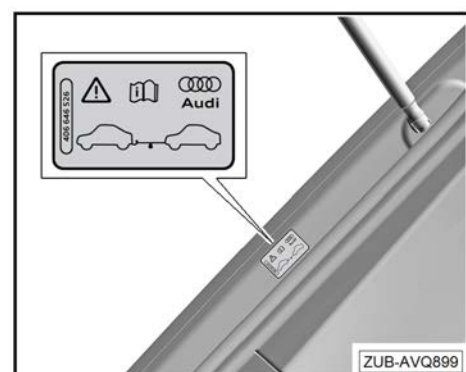



## 9.5 Adjusting the cooling system

As towing mode puts greater demands on the engine cooling system, the cooling system is upgraded – where technically possible – when the towing bracket is installed in the factory.

The cooling system does not need to be upgraded if it is possible to guarantee that the engine is only ever exposed to the following conditions:

- ◆ The weight of the combination falls below the permissible gross combination weight rating
- ◆ No high ambient temperatures
- ◆ No long, steep inclines
- ◆ No high altitude journeys

In any case, the coolant temperature display must be carefully monitored. If the needle in the display moves into the hot area, the speed must be reduced immediately. A cool-down time must also be allowed for if necessary. This involves the allowing the engine to idle for approx. 2 minutes to prevent a build-up of heat.

