

## Installation instructions

**AUDI Q5 (FY) 2017 ►**

**AUDI Q5 TFSI e (FY) 2020 ►**

**AUDI Q5 PU (FY) 2021 ►**

**AUDI Q5 Sportback (FY) 2021 ►**

**AUDI Q5 Sportback (FY) TFSI e 2021 ►**

**Swivelling towing bracket (ECE)  
for package number 80A.092.157.\*  
Audi Genuine Accessories**

Edition 03



## Contents

<b>1</b>	<b>General notes</b> .....	<b>1</b>
<b>2</b>	<b>Safety instructions for pyrotechnical, electrical and mechanical components of the restraint system</b> .....	<b>2</b>
2.1	General safety instructions .....	2
2.2	Storing, transporting and disposing of airbag, belt tensioner and battery disconnecter units (pyrotechnic components) .....	3
<b>3</b>	<b>Safety notes on the towing bracket – Fitting and operation</b> .....	<b>4</b>
3.1	Notes on the towing vehicle .....	4
3.2	Notes on the towing bracket .....	4
3.3	Safety notes on assembly .....	5
3.4	Safety notes on operation .....	6
3.5	Bicycle carrier safety instructions .....	9
3.6	Sensitivity to side winds: safety instructions .....	9
3.7	Notes concerning ECE-R 55 mechanical coupling device guidelines .....	10
<b>4</b>	<b>Overview of components</b> .....	<b>11</b>
4.1	Overview of mechanical components Q5 .....	9
4.2	Overview of electrical system components .....	13
4.3	Additional required parts .....	14
<b>5</b>	<b>Assembly overview and tightening torques</b> .....	<b>16</b>
5.1	Towing bracket with cross member .....	9
5.2	Luggage compartment electrical system .....	18
<b>6</b>	<b>Preparations</b> .....	<b>19</b>
6.1	Disconnecting the battery .....	20
6.2	Removing the following equipment .....	20
6.3	Releasing the fuse holder from the bracket for the convenience system central control unit -J393- .....	21
6.4	Release the convenience system central control unit -J393- holder .....	21
<b>7</b>	<b>Installing the towing bracket</b> .....	<b>22</b>
7.1	Fitting the towing bracket .....	22
7.2	Preparing the mounting holes .....	22
7.3	Trimming the left-hand foam section .....	24
7.4	Installing the towing bracket .....	25
<b>8</b>	<b>Electrical connection</b> .....	<b>27</b>
8.1	Assembly overview of the socket/electrical release retrofit wiring harness .....	22
8.2	Installing the bracket for the trailer detector control unit -J345- .....	27
8.3	Routing and connecting the socket/electrical release retrofit wiring harness .....	28
8.4	Connecting the onboard supply retrofit wiring harness .....	30



8.4.1	Pin assignment on the convenience system central control unit -J393-	30
8.4.2	Integrating the CAN bus	31
8.4.3	Connecting the brake light signal/terminal 15	33
8.4.4	Connecting the lighting for the electric swivelling towing bracket release button -E474- terminal 58s	35
8.5	Establishing a power supply	37
8.6	Connecting the onboard supply retrofit wiring harness to the trailer detector control unit -J345-	38
8.7	Adjusting the electrical connector for load sill lowering button -E539-	39
8.8	Installing the towing bracket electrical release button	40
<b>9</b>	<b>Concluding operations</b>	<b>41</b>
9.1	Reassembling the vehicle	41
9.2	Connecting the battery	41
9.3	Adapting the trailer detector control unit -J345- coding	41
9.4	Commissioning and functional check	41
9.5	Attach the information sticker	42
9.6	Adjusting the cooling system	42





# 1 General notes

Please read and take note of these WARNING, Caution and Note descriptions before carrying out maintenance or repair work.



## **WARNING**

***Text with this symbol contains information concerning your safety and indicates potential accident and injury risks.***



## **Caution**

***Text with this symbol indicates the risk of damage to your vehicle.***



## **Note**

*Text with this symbol contains additional information.*



## **Caution**

***Towing mode places increased demands on the cooling system.***

- ◆ ***The cooling system ⇒ Page 42 must be adapted to the vehicle operating conditions .***

Special tools are required for assembly. Improper installation can cause damage to the vehicle or the add-on parts.



## **WARNING**

***For safety reasons, the towing bracket must only be fitted by skilled personnel – risk of accident!***

***Additional modifications may be required – risk of accident. Detailed information can be found in these installation instructions.***

AUDI AG shall not accept responsibility in the event of failure to comply with these installation instructions.



## 2 Safety instructions for pyrotechnical, electrical and mechanical components of the restraint system

### 2.1 General safety instructions

Pyrotechnical components comprise:

- ◆ Airbag units
- ◆ Belt tensioners
- ◆ Belt force limiters
- ◆ Battery disconnecting elements

#### General

- ◆ Testing, installation and maintenance tasks must only be carried out by trained personnel.
- ◆ There are no replacement intervals for airbag units.
- ◆ Do not check using circuit tester, voltmeter, or ohmmeter under any circumstances.
- ◆ Pyrotechnic components must only be checked when installed and using ⇒ vehicle diagnostic testers that have been approved by the manufacturer.
- ◆ When working on pyrotechnic components and the airbag control unit -J234-, the battery earth wire must be disconnected when the IGNITION is SWITCHED ON. The battery negative terminal must subsequently be covered.
- ◆ You must wait ten seconds after the battery -A- has been disconnected.
- ◆ The battery -A- must be connected when the IGNITION is SWITCHED ON. There must not be anybody inside the vehicle during this process. Exception: vehicles with battery -A- located inside the vehicle. Do not sit within the airbag and seat belt deployment range.
- ◆ Observe the appropriate steps after connecting the battery -A-Cross reference error: reference link ID='X-UOTT0XTPEVB' not found.
- ◆ Before performing any work on pyrotechnic components in the restraint system, e.g. before disconnecting the electrical connector, the mechanic carrying out the task must discharge any static electricity. Electrostatic discharging can be performed by touching earthed metal parts, e.g. by briefly touching the door striker plate.
- ◆ Wash hands after touching ignited pyrotechnical components of the restraint system.
- ◆ Pyrotechnical components must neither be opened nor repaired. New parts must always be used (risk of injury).
- ◆ Pyrotechnic components that have fallen onto a hard surface or that show any sign of damage must not be installed.



- ◆ Pyrotechnic components must be installed immediately after they are removed from the transport container.
- ◆ If work is interrupted, the pyrotechnic component must be returned to the transport container.
- ◆ Pyrotechnic components must not be left unattended.
- ◆ When connecting the pyrotechnic components in the restraint system, only the person performing the work may be inside the vehicle.
- ◆ Pyrotechnic components must not be treated with grease, cleaning agents or similar products.
- ◆ If the fabric becomes contaminated with substances such as oil, grease, paint, colour or solvents, the airbag unit must be replaced.
- ◆ In addition, pyrotechnic components must not be exposed to temperatures above 100°C, even for short periods.

## 2.2 Storing, transporting and disposing of airbag, belt tensioner and battery disconnecter units (pyrotechnic components)

- ◆ Storage is subject to the applicable national legislation.
- ◆ Transportation is subject to national and international laws governing packaging, naming, labelling and accompanying documentation.
- ◆ Pyrotechnic components that have not been ignited must be returned in the original packaging for appropriate recycling in line with the applicable national legislation! Contact your importer if you have any questions.
- ◆ Only pyrotechnic components that have been completely ignited may be disposed of as industrial waste.

### **WARNING**

***This does not apply for belt tensioners that operate according to the Wankel tensioner principle. Tensioners of this kind should be handled in the same way as pyrotechnic components that have not been ignited (e.g. airbags).***

***Background: For belt tensioners that operate according to the Wankel tensioner principle, it is not possible to check whether all ignition stages have completed using workshop tools.***



### 3 Safety notes on the towing bracket – Fitting and operation

#### 3.1 Notes on the towing vehicle

Manufacturer:	AUDI AG
Model:	Q5 2017 ►, Q5 TFSI e 2020 ►, Q5 PU 2021 ►, Q5 Sportback 2021 ►, Q5 Sportback TFSI e 2021 ►
Offic. Type designation:	FY

Maximum trailer weight or trailer drawbar load in kg, as specified by the manufacturer for the above-named vehicle model: ⇒ Vehicle registration certificate/Owner's Manual.

#### 3.2 Notes on the towing bracket

Technical data	Vehicles with steel-spring suspension/air suspension
Bosal no. Q5 2017 ►, Q5 PU 2021 ►, Q5 Sportback 2021 ►:	E520
Bosal no. Q5 TFSI e 2020 ►, Q5 Sportback TFSI e 2021 ►:	E560
ECE no. Q5 2017 ►, Q5 PU 2021 ►, Q5 Sportback 2021 ►:	E1 55R-01 2405
ECE no. Q5 TFSI e 2020 ► Q5 Sportback TFSI e 2021 ►:	E1 55R-01 2772
D-value Q5 2017 ►, Q5 PU 2021 ►, Q5 PU Sportback 2021 ►:	12.6 kN
D-value Q5 TFSI e 2020 ►, Q5 Sportback TFSI e 2021 ►:	11.6 kN
Permitted trailer drawbar load:	100 kg



#### **WARNING**

***The drawbar load figures specified on the towing bracket identification plate are only given as test values. Vehicle-specific figures are often lower than these values and can be found in the vehicle documents.***

Please see your vehicle documents for your maximum trailer weight.



#### **WARNING**

***Do not exceed the verified D-value and the permitted trailer drawbar load – risk of accident!***

The towing bracket is intended for towing trailers fitted with a tow ball and for operating carriers suitable for mounting to the coupling ball.

Nationally applicable regulations must be adhered to in EU and non-EU countries.

Improper use is prohibited.

Use is only permitted under favourable road conditions and must be adapted to road conditions.



### 3.3 Safety notes on assembly

 **WARNING**

***For safety reasons, the towing bracket must only be fitted by skilled personnel – risk of accident!***

- ◆ ***If replacement parts are required, these must only be installed by skilled personnel and to undamaged genuine parts – risk of accident!***
- ◆ ***Installation must be in line with AUDI AG/Volkswagen AG guidelines – risk of accident!***
- ◆ ***Modification of the towing bracket is prohibited. This will invalidate the type approval – risk of accident and legal implications!***
- ◆ ***Use of the mounting points approved as standard by the vehicle manufacturer is mandatory – risk of accident!***

 **Caution**

***Towing mode places increased demands on the cooling system.***

- ◆ ***Consult a qualified AUDI AG/Volkswagen AG workshop should modifications to the cooling system be required. Further notes can be found in the “towing mode” guidebook.***
- Remove underbody sealing, body cavity sealant (wax) or insulation material from the area around the contact surfaces of the towing bracket with the vehicle.
- In order to provide adequate corrosion protection to bare metal body parts, apply the following products with a brush.
  - ◆ Single-component primer surfacer LGF.008.001.42/43
  - ◆ Two-component HS vario surfacer LGF.786.004.A4
  - ◆ Paint to match the vehicle colour
  - ◆ Body cavity preserving agent D.330.KD2.A1



### 3.4 Safety notes on operation

 **WARNING**

**Vehicle handling is affected by the use of towing mode; increased driver awareness is required – risk of accident!**

- ◆ **Read the notes in the “Towing mode” chapter of the ⇒ Owner's Manual – risk of accident!**
- ◆ **If you are using trailer stabilisers, the coupling ball must be free from grease. Read and observe the notes in the relevant Owner's Manuals – risk of accident!**

**The diameter of the ball coupling must be checked at regular intervals.**

- ◆ **For safety reasons, use of the towing bracket must be discontinued if the diameter reaches 49 mm at any point. If this situation occurs, contact a qualified workshop – risk of accident!**

**For safety reasons, you are advised to swivel the ball rod inwards when not in use – risk of accident!**

 **Caution**

**The ball coupling must always be kept clean. A cover must be used.**

 **Note**

- ◆ *The towing bracket including all assembly parts weighs approx. 26 kg.*
- ◆ *Please note that the kerb weight of your vehicle will increase by this amount once the towing bracket is fitted.*
- ◆ *Please make sure that you do not exceed the gross vehicle weight rating for your vehicle.*

 **Note**

*Use the towing bracket when towing.*



Applies to Q5, Q5 PU and Q5 Sportback:

- 1 - Towing bracket with cross member and swivel system
- 2 - Coupling point for connecting wire to trailer detector control unit -J345-
- 3 - Ball coupling with protective cap
- 4 - Eye  
 for the brake cable
- 5 - Trailer socket on ball neck
- 6 - Connector for electrical release for swivel system

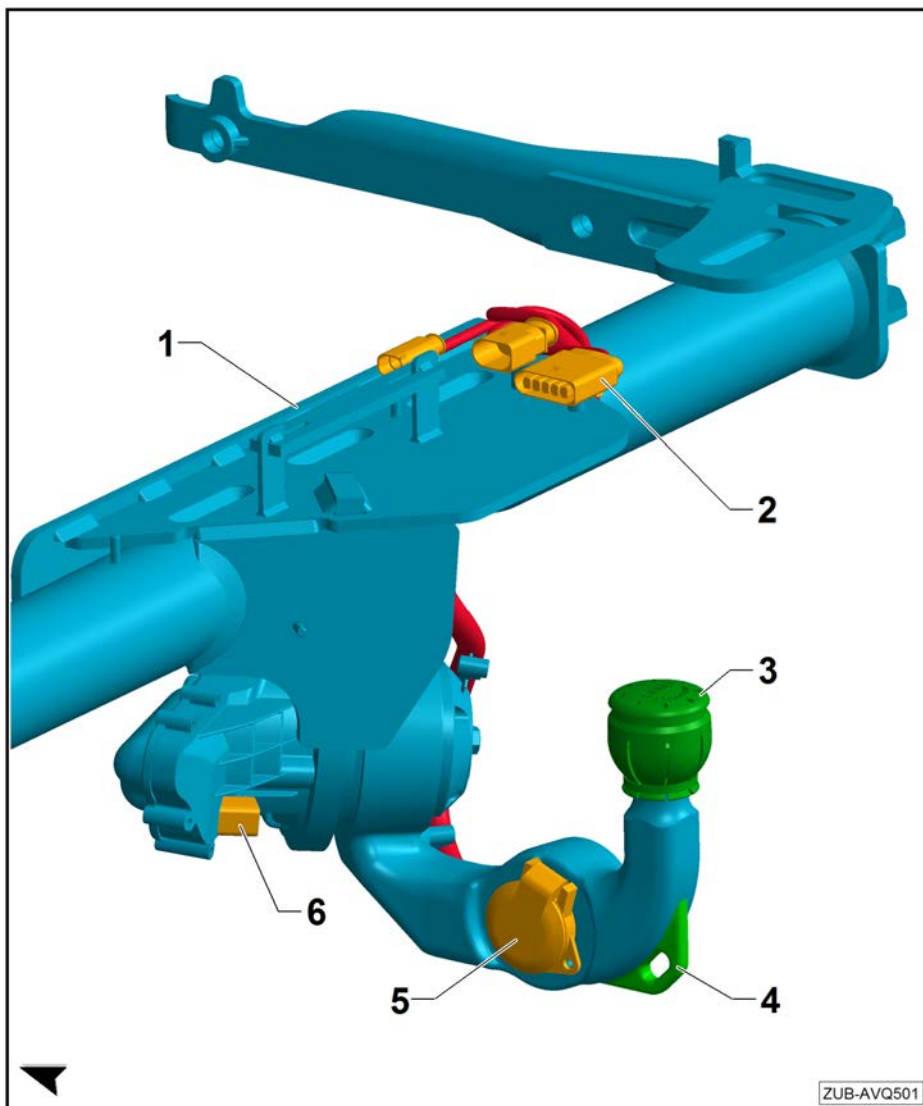



Applies to Q5 TFSI e, Q5 Sportback TFSI e:

- 1 - Towing bracket with cross member and swivel system
- 2 - Overhead mounting point
- 3 - Lateral mounting point
- 4 - Coupling point for connecting wire to trailer detector control unit -J345-
- 5 - Ball coupling with protective cap
- 6 - Eye  
 for the brake cable
- 7 - Trailer socket on ball neck
- 8 - Connector for electrical release for swivel system

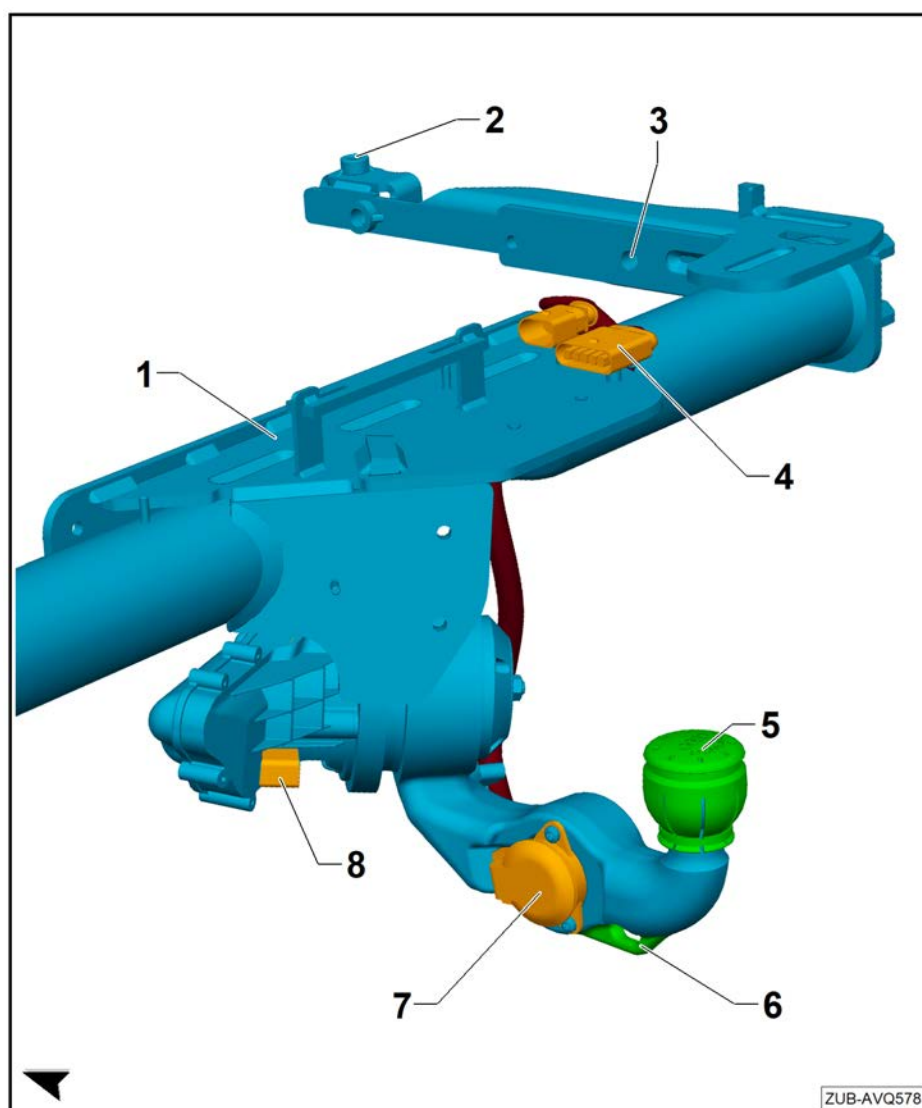

Next steps for all vehicles:

**⚠ Caution**

**The ball coupling must always be kept clean.**

**i Note**

- ◆ The towing bracket including all assembly parts weighs approx. 26 kg.
- ◆ Please note that the kerb weight of your vehicle will increase by this amount once the towing bracket is fitted.
- ◆ Please make sure that you do not exceed the gross vehicle weight rating for your vehicle.

**i Note**

Use the towing bracket ball coupling to tow trailers.



**⚠ WARNING**

**Do not tow using the eye – risk of breakage!**

**A protective cap can be fitted on the ball head when swivelling in the ball coupling.**

### 3.5 Bicycle carrier safety instructions

**⚠ WARNING**

**The bicycle carrier for the trailer towing coupling is only suitable for transporting bicycles – risk of accident!**

- ◆ **The towing bracket bicycle carrier must only be used to transport bicycles with a total weight of max. 60 kg (132 lbs). When carrying bicycles, the distance from the end of the vehicle to the last bicycle must not exceed 60 cm.**
- ◆ **The bicycle carrier for trailer towing coupling is not suitable for off-road use.**
- ◆ **Do not under any circumstances exceed the maximum load of the bicycle carrier for trailer towing coupling or the drawbar load of the trailer towing coupling.**
- ◆ **The combined weight of the towing bracket bicycle carrier and bicycles must not exceed the gross vehicle weight rating or the gross axle weight rating of the vehicle (⇒ owner's manual).**

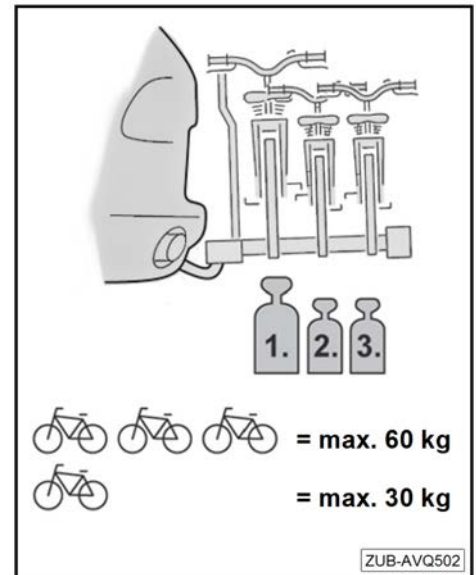

### 3.6 Sensitivity to side winds: safety instructions

**⚠ WARNING**

**The load affects driving and braking behaviour and the vehicle's sensitivity to side winds. Adapt your driving style accordingly – risk of accident!**

**When driving in strong side winds, make sure that you take extra care:**

- ◆ **When moving into and out of the slipstreams of lorries,**
- ◆ **When driving past hedgerows, trees, walls and buildings as well as any other wind barriers,**
- ◆ **When driving over bridges.**



### 3.7 Notes concerning ECE-R 55 mechanical coupling device guidelines

Make sure that clearance is provided in compliance with appendix 7, Figure 25a and 25b of the guideline ECE-R 55.

- 1 - Clearance
- 2 - Vertical plane through the end points of the vehicle's overall length
- 3 - Ground

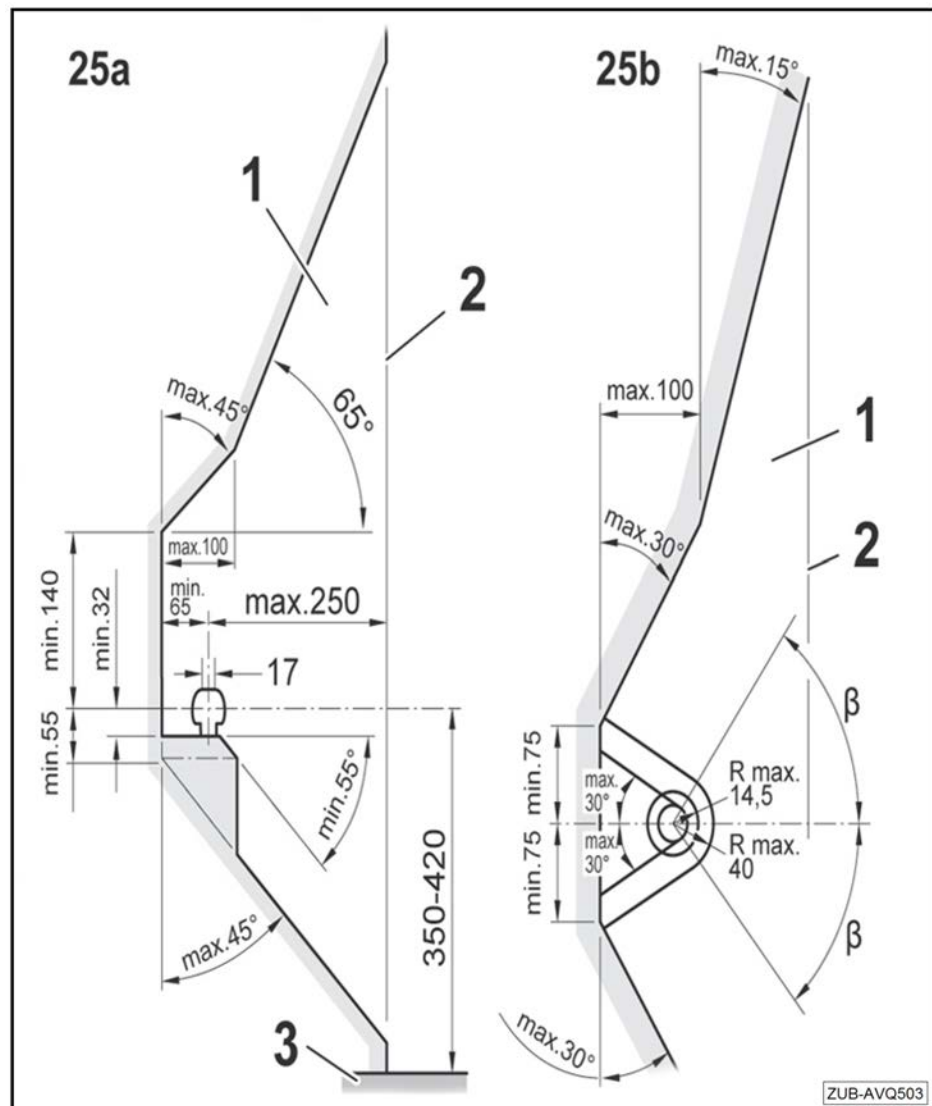

## 4 Overview of components

### 4.1 Overview of mechanical components Q5

Applies to Q5, Q5 PU and Q5 Sportback:

- 1 - Cross member with swivel system incl. electrical connector for the socket and electrical release wiring harness
- 2 - Coupling point for connecting wire to trailer detector control unit -J345-
- 3 - Ball coupling with protective cap
- 4 - Trailer socket on ball neck
- 5 - Connector for electrical release for swivel system
- 6 - Foam sections right and left
- 7 - Information sheet
- 8 - Bolt with washer for securing the towing bracket
  - M12 x 60
  - 70 Nm + 180°
  - 4x

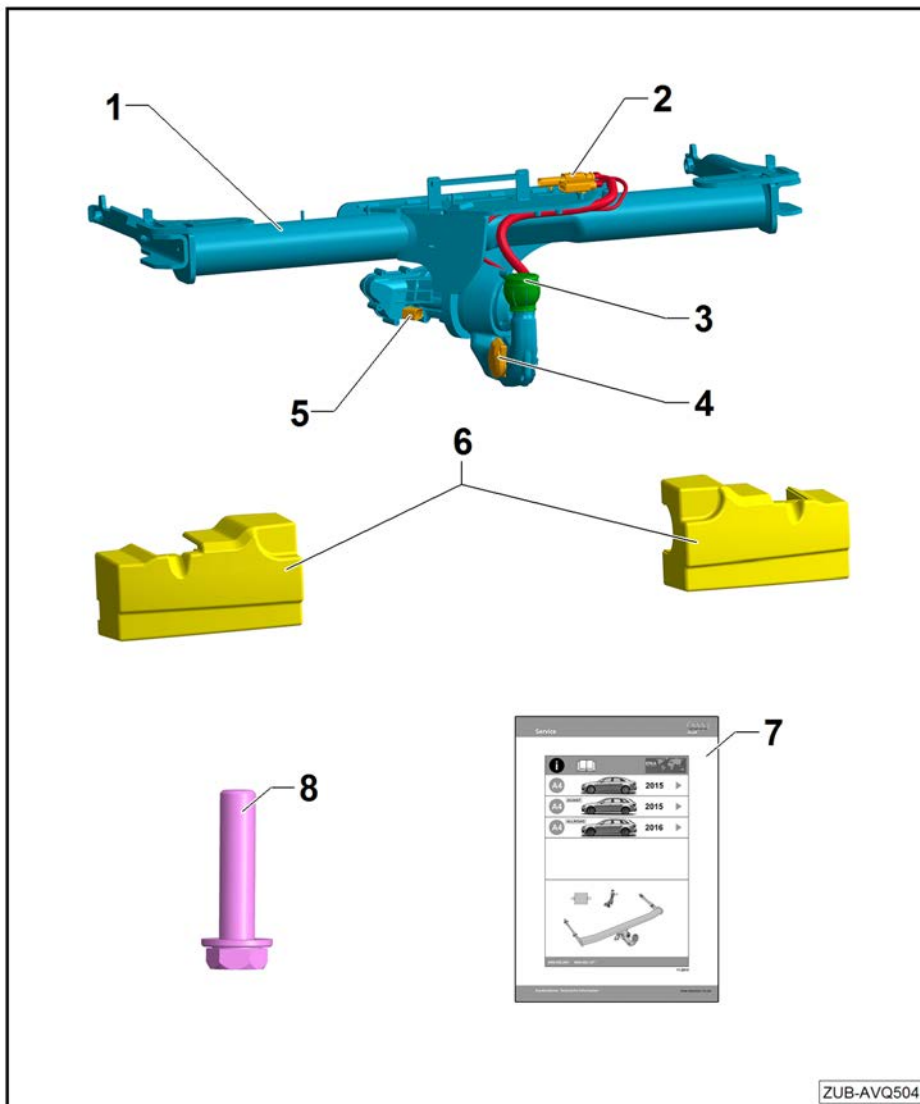



Applies to Q5 TFSI e, Q5 Sportback TFSI e:

- 1 - Cross member with swivel system incl. electrical connector for the socket and electrical release wiring harness
- 2 - Coupling point for connecting wire to trailer detector control unit -J345-
- 3 - Ball coupling with protective cap
- 4 - Trailer socket on ball neck
- 5 - Connector for electrical release for swivel system
- 6 - Foam sections right and left
- 7 - Information sheet
- 8 - Bolt with washer for the overhead mounting point of the towing bracket
  - M10 x 45
  - 60 Nm + 180°
  - 2x
- 9 - Bolt with washer for the lateral mounting point of the towing bracket
  - M12 x 60
  - 70 Nm + 180°
  - 2x

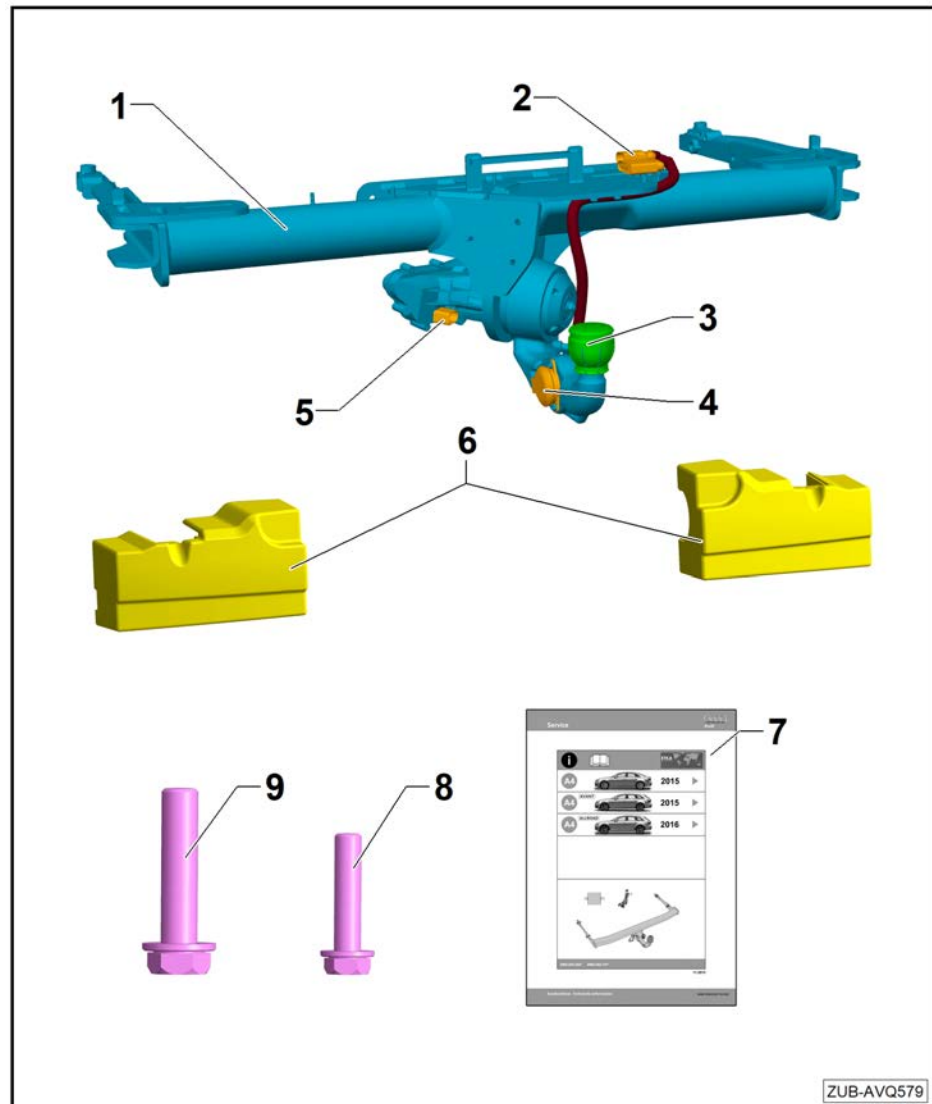



## 4.2 Overview of electrical system components

Next steps for all vehicles:

**1 - Retrofit wiring harness between the electrical connector for the socket/electrical release wiring harness and the trailer detector control unit -J345-**

**2 - Onboard supply retrofit wiring harness**

- LHD/RHD (swivelling)
- 1x

**3 - PE bag**

- 1x

**Note**

Attached to the onboard supply wiring harness.

Contents

- Socket housing with 3 compartments (1x), black
- Socket housing with 3 compartments (1x), white
- Socket housing with 2 compartments (1x), black

**4 - "Towing with towing bracket" sticker**

- 1x

**5 - Cable ties**

- 10x

**6 - Fitting trailer detector control unit -J345-**

- 1x

**7 - Adhesive spots**

- 4x

**8 - 15 A fuse**

- 2x

**9 - 25 A fuse**

- 2x

**10 - Information sheet – assembly instructions**

- 1x

**11 - Activation document**

- 1x

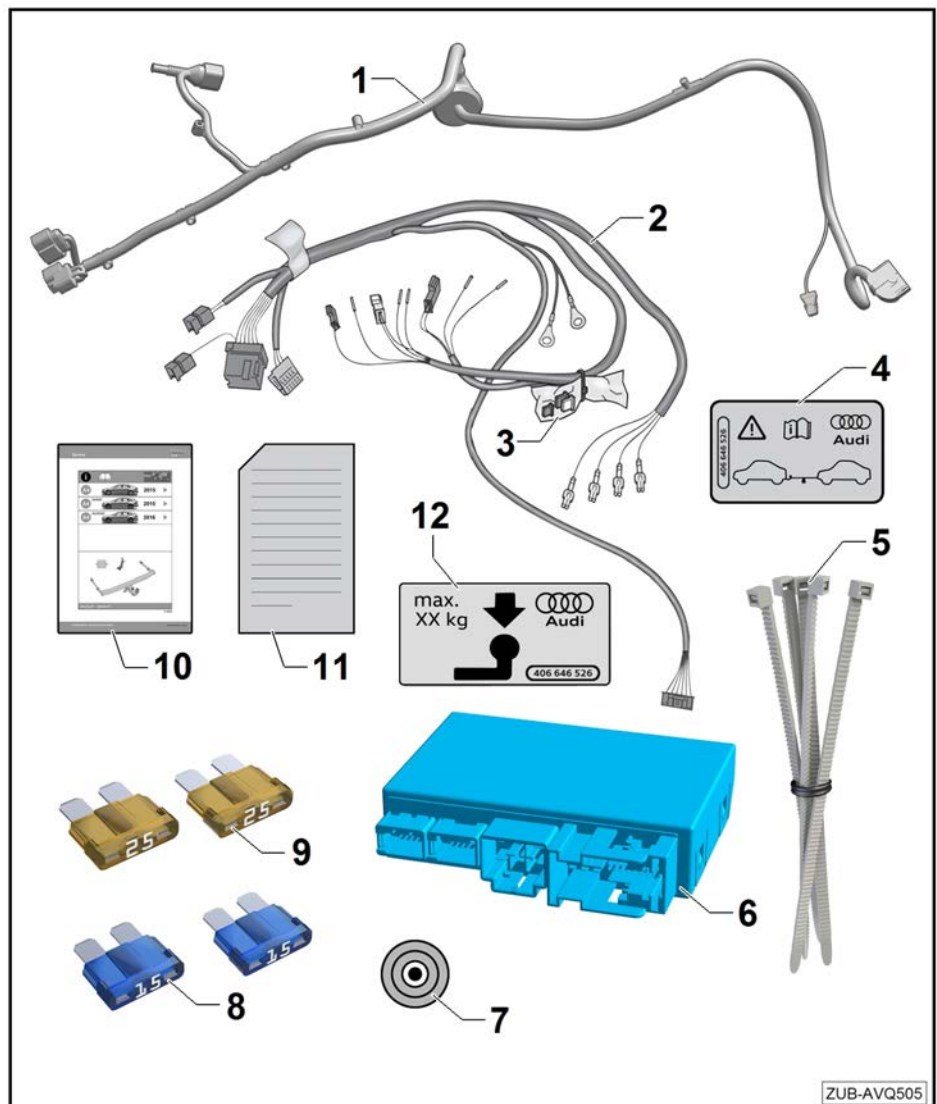

ZUB-AVQ505



## 12 - Drawbar load sticker

□ 1x

### 4.3 Additional required parts

Order and fit on vehicles with 1D0+KA0/KA2 or 1D8+KA0/KA2:

Bracket 80A.907.297 -1-⇒ Electronic parts catalogue

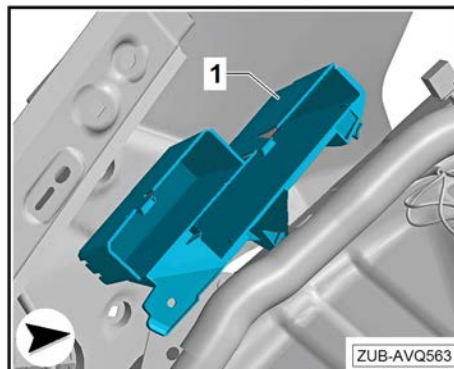

Order and fit according to equipment:

#### Note

Before ordering, check whether the bumper has a recess (on vehicles with preparation) for the towing bracket.

Applies to Q5 2017 ►, Q5 TFSI e 2020 ►

Bumper fitted without towing bracket	Replace with:
80A.807.434.B (= 80A.807.521.B + 80A.807.941) BASIC (2K5/2K6/VJ1/VJ5/VJ8)	80A.807.434.C (= 80A.807.521.C + 80A.807.941.B)
80A.807.434 (= 80A.807.521 + 80A.807.941) BASIC (2K1)	80A.807.434.A (= 80A.807.521.A + 80A.807.941.B)
80A.807.434.D (= 80A.807.521.D + 80A.807.941.C) S-LINE/S (2K3/2K7)	80A.807.434.E (= 80A.807.521.E + 80A.807.941.A)

Applies to Q5 PU 2021 ►

Bumper fitted without towing bracket	Replace with:
80A.807.434.F (= 80A.807.521.K + 80A.807.941.C) (S-LINE/S (2K3/2K7/2K8/2K9)	80A.807.434.G (= 80A.807.521.L + 80A.807.941.A)

Q5 Sportback 2021 ►, Q5 Sportback TFSI e 2021 ►

Bumper fitted without towing bracket	Replace with:
80F.807.434 (= 80F.807.521.B + 80A.807.941.C)	80F.807.434.A (= 80F.807.521.C + 80A.807.941.A)

#### Note

The complete bottom part of the bumper must be replaced and painted!

Bottom part of the bumper ⇒ Electronic parts catalogue

Order and fit according to equipment:



<b>Switch to trigger towing bracket unlock</b>	<b>Replace with:</b>
No switch fitted	80A.959.511.A + 80A.867.255
4M0.959.511.E	80A.959.511



## 5 Assembly overview and tightening torques

### 5.1 Towing bracket with cross member

Applies to Q5 2017 ►, Q5 PU 2021 ►, Q5 Sportback 2021 ►:

**1 - Towing bracket with cross member and right/left foam sections**

- Assembly  
⇒ Page 22

**2 - Securing bolts, left and right**

- M12 x 60
- 70 Nm + 180°
- (4x)
- Replace after removal

**3 - Electrical connector for socket retrofit wiring harness**

**4 - Electrical connector for electrical release retrofit wiring harness**

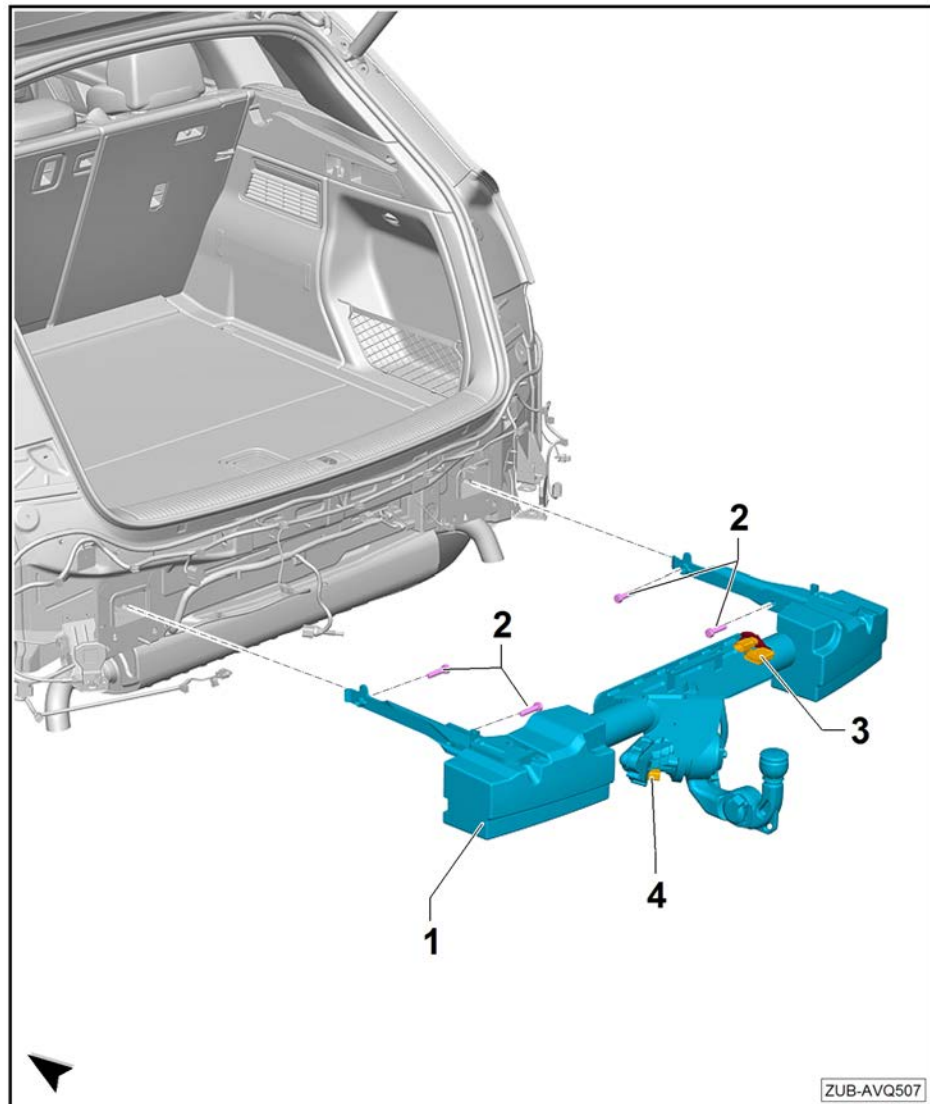

Applies to Q5 TFSI e, Q5 Sportback TFSI e:

**1 - Towing bracket with cross member and right/left foam sections**

- Assembly

**2 - Securing bolts A and B**

Lateral mounting point

- M12 x 60
- 70 Nm + 180°
- (2x)
- Replace after removal

**3 - Securing bolts C and D**

Overhead mounting point

- M10 x 45
- 60 Nm + 180°
- (2x)
- Replace after removal

**4 - Electrical connector for socket retrofit wiring harness**

**5 - Electrical connector for electrical release retrofit wiring harness**

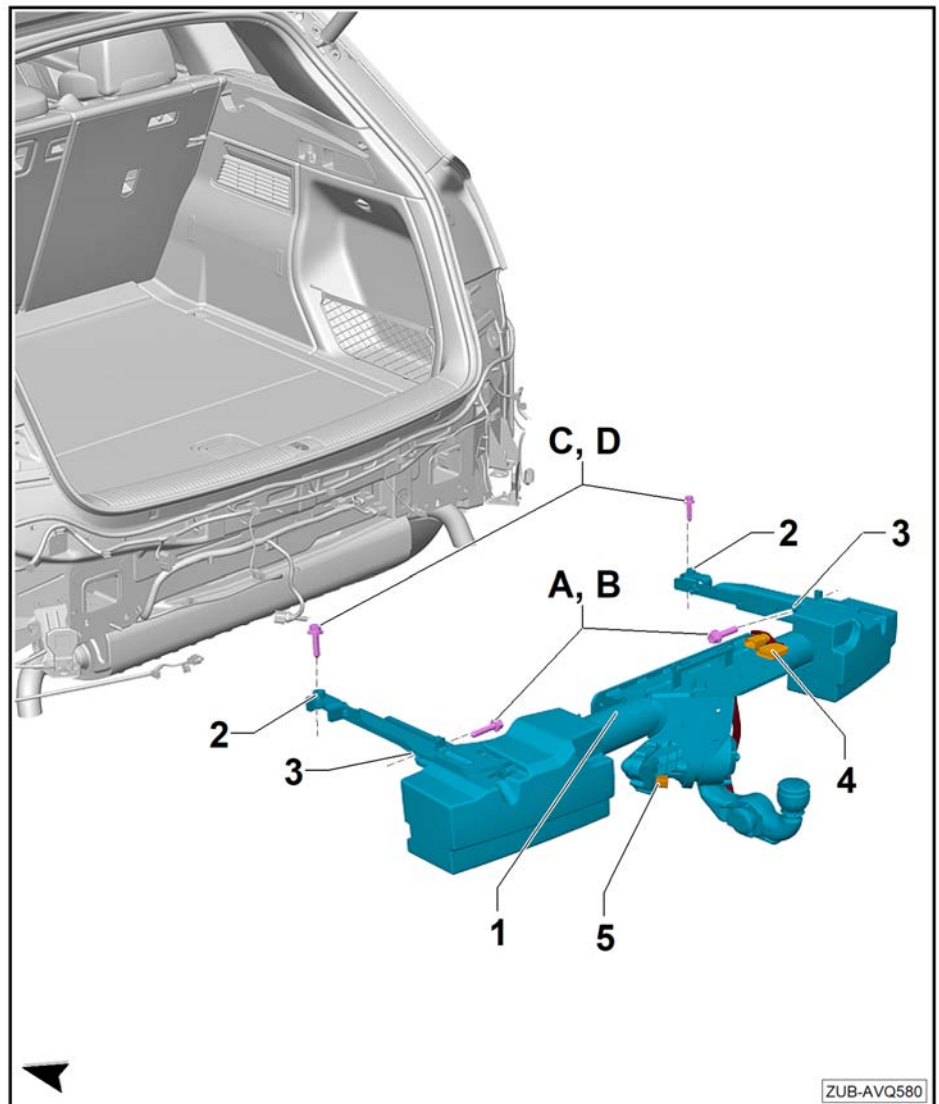



## 5.2 Luggage compartment electrical system

Next steps for all Q5 vehicles:

**1 - Bracket for trailer detector control unit -J345-**

- Additional required parts

**2 - Fitting trailer detector control unit -J345-**

**i Note**

Also order the bracket for the control unit according to equipment.

- Additional required parts → [Page 14](#)

**3 - Electrical connector for swivelling towing bracket electrical release button**

- On onboard supply retrofit wiring harness

**4 - Earth stud on left in luggage compartment**

- 9 Nm

**5 - Onboard supply retrofit wiring harness**

**6 - Socket/electrical release retrofit wiring harness**

**7 - Relay and fuse holder F in the rear left of the luggage compartment**

**8 - Convenience system central control unit -J393-**

- Below the cover

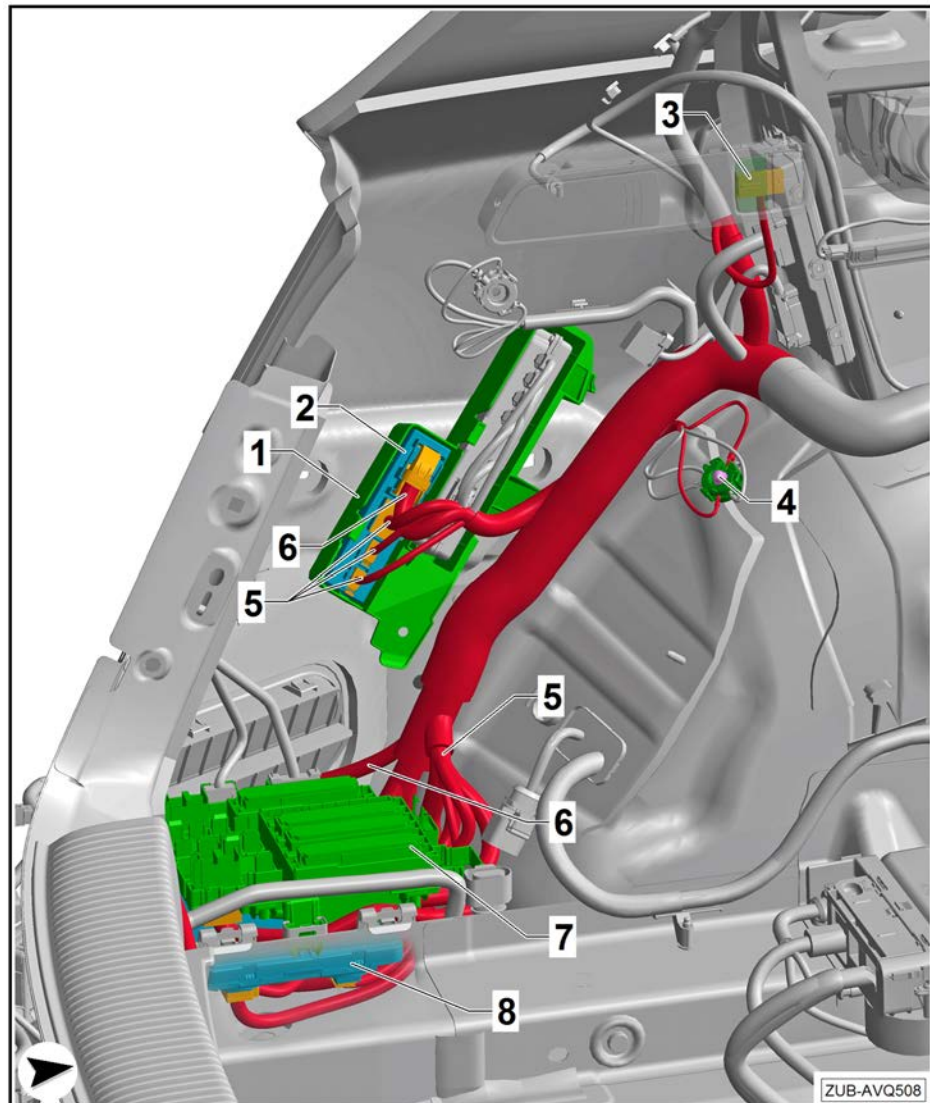

## 6 Preparations

### Required special tools, testing instruments, measuring instruments and auxiliary devices

- ◆ Torque wrench -V.A.G 1410-

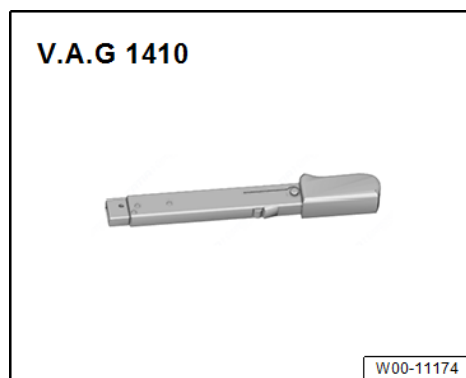

- ◆ Torque wrench -V.A.G 1332-



- ◆ Removal lever -80 - 200-

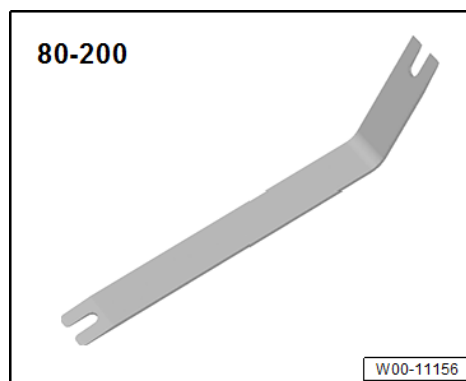

- ◆ Wedge -3409-

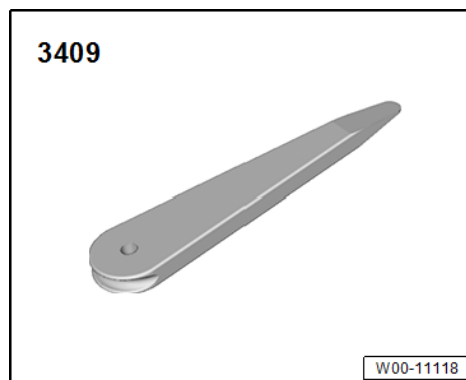



## 6.1 Disconnecting the battery

- Disconnect the battery ⇒ Electrical system; Rep. gr. 27; Battery; Disconnecting and connecting the battery

### **WARNING**

- ◆ ***Always make sure that the vehicle's electrical system is protected by disconnecting the battery before performing work on the electrical system.***
- ◆ ***Only unscrew the battery negative terminal (-) of the battery.***
- ◆ ***The battery positive terminal (+) of the battery must only be unscrewed once the battery has been removed from the vehicle.***

## 6.2 Removing the following equipment

### **Applies to all vehicles:**

- Remove the luggage compartment floor mat - Equipment variant ⇒ General body repairs, Interior; Rep. gr. 70; Luggage compartment trims; Removing and installing the luggage compartment floor mat
- Remove the subwoofer -R211- - Equipment variant ⇒ Communication; Rep. gr. 91; Sound system; Removing and installing the subwoofer -R211-
- Remove the front luggage compartment floor – Equipment variant ⇒ General body repairs, Interior; Rep. gr. 70; Luggage compartment trims; Removing and installing the front luggage compartment floor
- Remove the rear lid lock trim ⇒ General body repairs, interior; Rep. gr. 70; Luggage compartment trim; Removing and installing the rear lid lock trim
- Remove the fastening rings ⇒ General body repairs, Interior; Rep. gr. 70; Luggage compartment trims; Removing and installing the fastening rings
- Remove the rear shelf ⇒ General body repairs, interior; Rep. gr. 70; Interior trims; Removing and installing the rear shelf
- Remove the left and right luggage compartment lights -W3- ⇒ Electrical system; Rep. gr. 96; Lights; Removing and installing the left and right luggage compartment lights -W3-
- Remove the luggage compartment side trim ⇒ General body repairs, Interior; Rep. gr. 70; Luggage compartment trims; Removing and installing the luggage compartment side trim
- Assembly overview of the bumper cover ⇒ General body repairs, Exterior; Rep. gr. 63; Rear bumper; Assembly overview of the bumper cover
- Remove rear bumper cover ⇒ General body repairs, Exterior; Rep. gr. 63; Rear bumper; Removing and installing the bumper



- Assembly overview of the impact bar ⇒ General body repairs, Exterior; Rep. gr. 63; Rear bumper; Assembly overview of the impact bar
- Remove the impact bar ⇒ General body repairs, Exterior; Rep. gr. 63; Rear bumper; Removing and installing the impact bar
- Remove the heat shield from underneath the impact bar.

**According to equipment, also remove:**

- Premium-sound amplifier
- Bracket for premium-sound amplifier

### 6.3 Releasing the fuse holder from the bracket for the convenience system central control unit -J393-

**Applies to all vehicles:**

- Loosen fastener -2- and pull fuse holder -1- upwards slightly. Detach fuse holder -1- from the tabs -3- and remove it upwards. Place the fuse holder -1- to one side.

**Note**

*The electrical wires remain connected.*

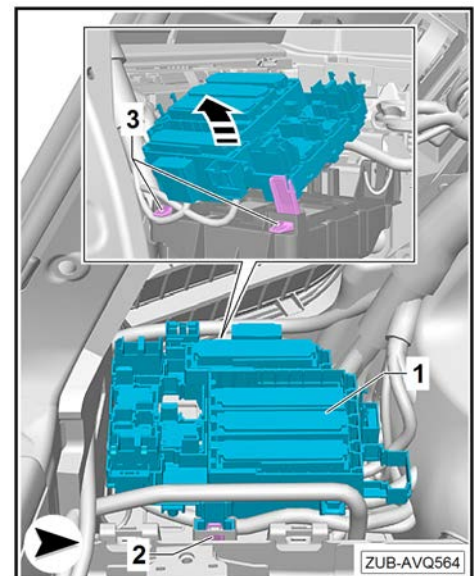

### 6.4 Release the convenience system central control unit -J393- holder

- Remove the mounting nuts -1-.
- Release the bracket -3- on the fasteners -2- and pull upwards with the convenience system central control unit -J393- -direction of arrows-.
- Put the convenience system central control unit -J393- and holder -3- to one side. The electrical wiring remains connected.

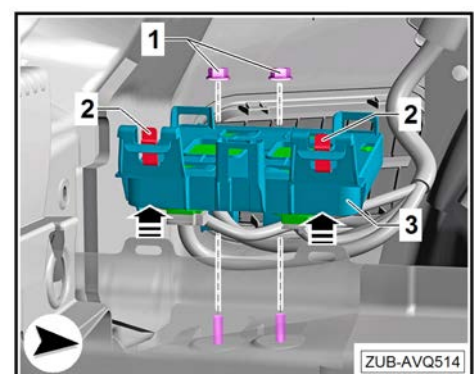



## 7 Installing the towing bracket

### 7.1 Fitting the towing bracket

Applies to all Q5:

**Special tools and workshop equipment required**

- ◆ Hot air blower
- ◆ Cartridge gun for bodywork sealant

**Preparatory work**

#### ⚠ Caution

**The body fold and threaded holes must be sealed using a suitable bodywork sealant to prevent any moisture from entering them.**

**Seal the holes of the detached damper**

#### **i** Note

The area of the bonding surfaces on the rear of the vehicle must be cleaned. Treat bare metal body parts with anti-rust paint.

- Stick the adhesive spots -A- onto the holes and heat using a hot air blower.

#### **i** Note

Applying heat to the adhesive spots increases their elasticity and bonds them with the body.

**Seal the longitudinal member body fold**

#### **i** Note

The area of the bonding surfaces around the body folds must be cleaned. Treat bare metal body parts with anti-rust paint.

- Seal the body fold of longitudinal member -B- on the right, left and in the upper area using bodywork sealant.

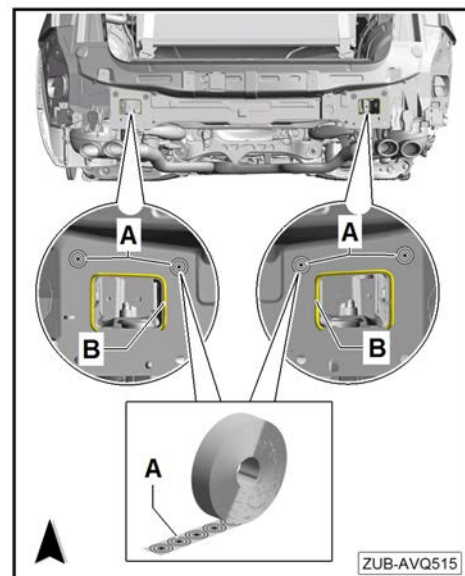

### 7.2 Preparing the mounting holes

Applies only to Q5 2017 ►:

#### **i** Note

- ◆ If the securing bolts on the towing bracket are changed, the size of the holes on the longitudinal member may have to be increased from 12 mm to 14 mm.
- ◆ Does not apply to all vehicles!
- ◆ Measure the holes beforehand using a suitable workshop tool.
- ◆ Holes measuring 12 mm must be increased to 14 mm.



### Special tools and workshop equipment required

- ◆ Stepped drill -1- (suggestion: Multi-TT Förch 5\*)
- ◆ Power drill
- ◆ Two-component wash primer LLS MAX 230 M1
- ◆ Two-component HS performance filler LLS MAX 973 M1
- ◆ Silicone remover LLS MAX 007

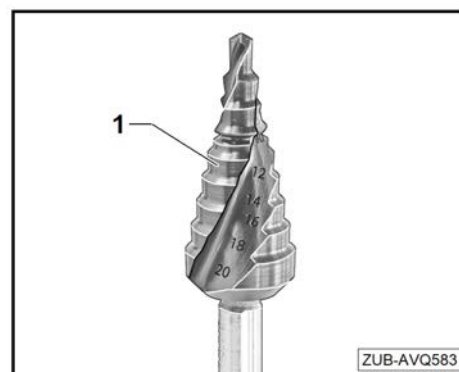

- ◆ Applicator D 009 500 25
- ◆ Body cavity preserving agent D 330 KD2 A1

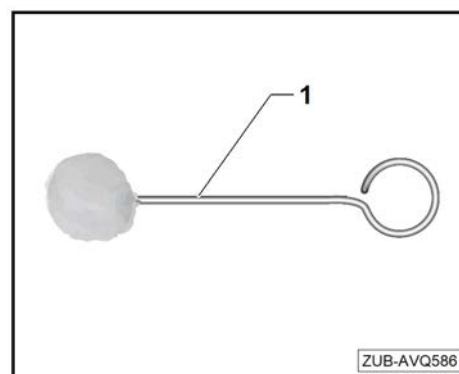

### Drilling the holes

- Drill four holes measuring -14 mm- in the longitudinal member using a step drill.

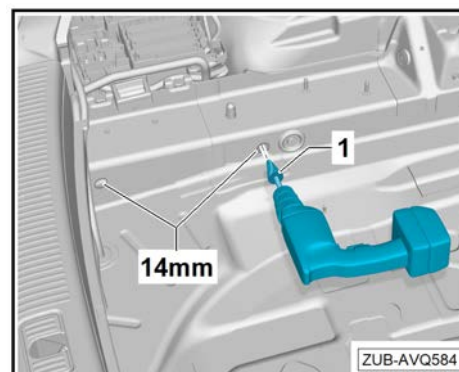

- Deburr the holes across the rim -2-.
- Remove any drilling chips using a suitable workshop tool.

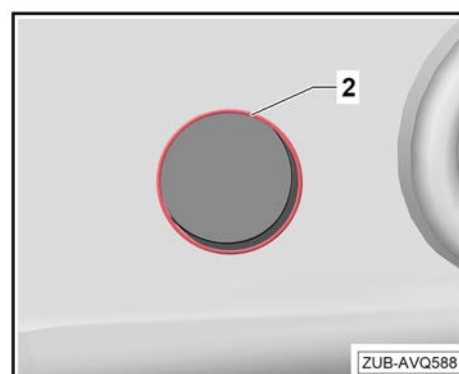

**⚠ WARNING**  
**The holes must be sealed using sufficient paint layers to prevent any moisture from entering the holes and prevent any corrosion.**  
**See also ⇒ Paintwork Guideline**

Apply new paint layers to the holes.

**⚠ WARNING**  
**Please observe the ⇒ Paintwork Guideline**



- Clean the hole -2- using silicone remover.

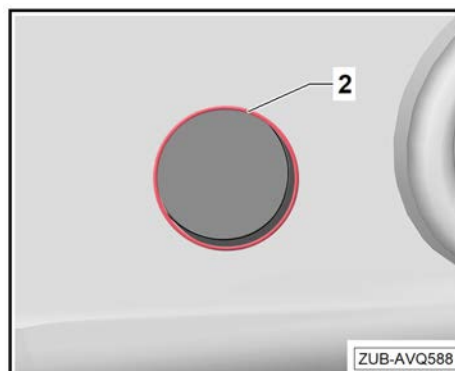

- Apply the two-component wash primer to the inside and outside of the exposed areas of the hole using the applicator -1-.
- Insert the applicator -1- in the -direction of the arrow A- and pull it back out again in the -direction of the arrow B-.
- Note the airing time of the two-component wash primer.
- Repeat the steps for applying the two-component wash primer.

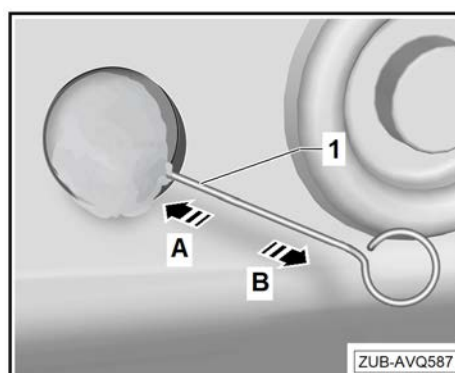

- Apply the two-component HS performance filler to the inside and outside of the primed areas of the hole using the applicator -1-.
- Insert the applicator -1- in the -direction of the arrow A- and pull it back out again in the -direction of the arrow B-.
- Note the airing time of the two-component HS performance filler.
- Repeat the steps for applying the two-component HS performance filler.
- Spray cavity sealant onto the area with the holes on the longitudinal member.

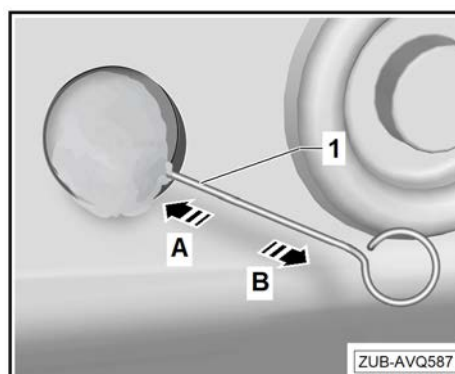

### 7.3 Trimming the left-hand foam section

Applies only to Q5 PU 2021 ►, Q5 Sportback 2021 ►, Q5 Sportback TFSI e 2021 ►

 **Note**

*Check whether the foam section has been trimmed. If this is not the case, proceed as follows.*



- Trim the foam section using suitable workshop equipment, otherwise it will come into contact with the LTE aerial.
- ◆ Dimension a = 38 mm
- ◆ Dimension b = 30 mm

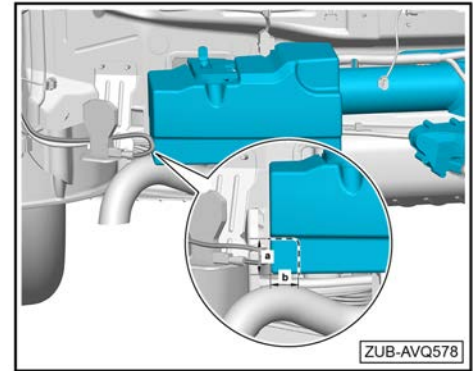

## 7.4 Installing the towing bracket

**Applies only to Q5, Q5 PU and Q5 Sportback:**

- Position the towing bracket on the longitudinal member and push in place with the help of a second technician.

### ⚠ Caution

**Make sure that the towing bracket is handled and transported correctly. Only transport the towing bracket using the transport eye on the cross member. The ball coupling must not be placed under load in the resting position.**

- Remove adhesive spots in the luggage compartment that are covering the mounting holes on the longitudinal member.
- Insert M12 bolts -A to D- on the left and right on the inside for securing the towing bracket and tighten the bolts by hand.
- Align the towing bracket and tighten bolts -A, D, B and C in that order- to the specified torque  
⇒ Page 16

### ⚠ WARNING

**Securing bolts must only be used once.**

- Fit the foam sections onto the cross member for the towing bracket.

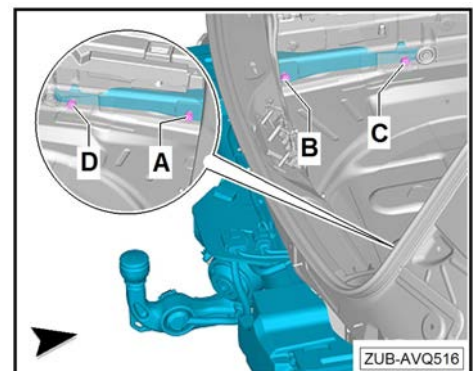

**Applies only to Q5 TFSI e, Q5 Sportback TFSI e:**

- Position the towing bracket on the longitudinal member and push in place with the help of a second technician.

### ⚠ Caution

**Make sure that the towing bracket is handled and transported correctly. Only transport the towing bracket using the transport eye on the cross member. The ball coupling must not be placed under load in the resting position.**

- Remove adhesive spots in the luggage compartment that are covering the mounting holes on the longitudinal member.



- Insert M12 bolts -A and B- on the left and right on the inside for securing the towing bracket and tighten the bolts by hand.
- Insert M10 bolts -C and D- on the left and right on the inside for securing the towing bracket and tighten the bolts by hand.
- Align the towing bracket and tighten bolts -A, D, B and C in that order- to the specified torque  
⇒ Page 16



**WARNING**

***Securing bolts must only be used once.***

- Fit the foam sections onto the cross member for the towing bracket.

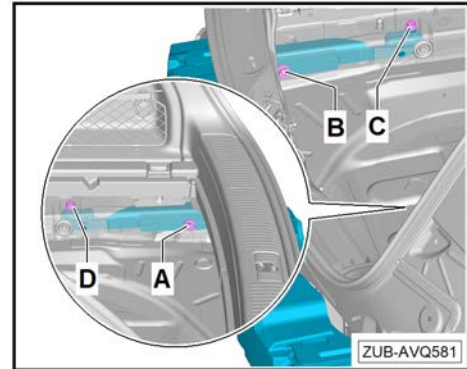



## 8 Electrical connection

### 8.1 Assembly overview of the socket/electrical release retrofit wiring harness

Next steps for all vehicles:

**1 - Fitting trailer detector control unit -J345-**

**2 - Earth stud**

- Luggage compartment, left
- 9 Nm

**3 - Routing of onboard supply retrofit wiring harness**

**4 - Convenience system central control unit -J393-**

- CAN bus connection
- Brake light/terminal 15 connection
- Terminal 58s connection

**5 - Routing of socket/electrical release retrofit wiring harness**

**6 - Wiring connection, power supply to fuse carrier ST5**

- Fuse 5: 25 A
- Fuse 7: 15 A
- Fuse 8: 25 A
- Fuse 9: 15 A

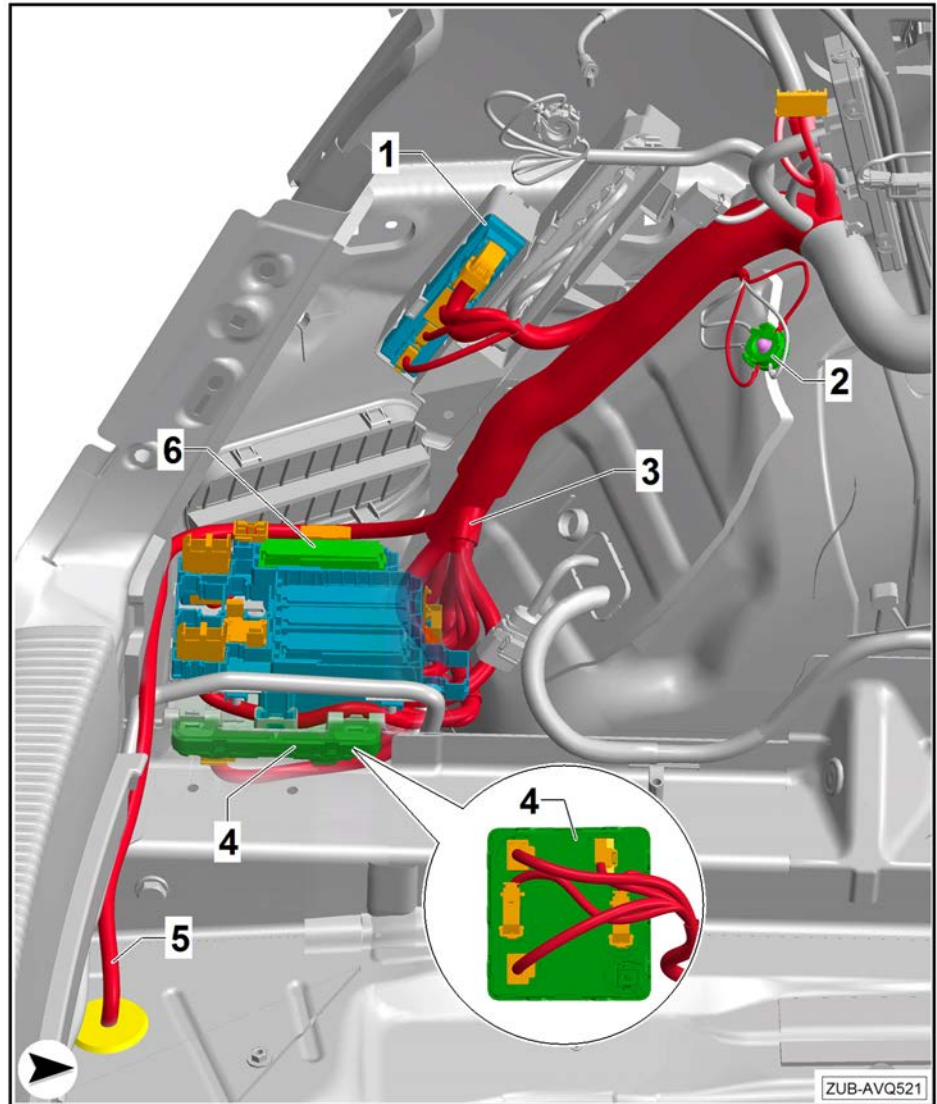

### 8.2 Installing the bracket for the trailer detector control unit -J345-

Applies to vehicles with 1D0+KA0/KA2 or 1D8+KA0/KA2

**Note**

Order bracket 80A.907.297 ⇒ *Electronic parts catalogue*



- Insert bracket -1- for the trailer detector control unit -J345- in the direction of arrow A-
- Push the bracket -1- for the trailer detector control unit -J345- downwards in the direction of arrow B- and secure with bolt -3-.
- Insert the trailer detector control unit -J345- into the assembled control unit bracket and snap in place.

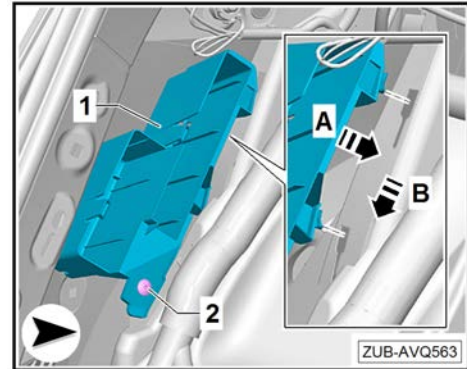

### 8.3 Routing and connecting the socket/ electrical release retrofit wiring harness

#### According to equipment

- Connect all of the connectors -2- present on the socket/electrical release retrofit wiring harness -1- with the coupling point -arrows-. Also connect the connector -4- for the swivel motor -3-.

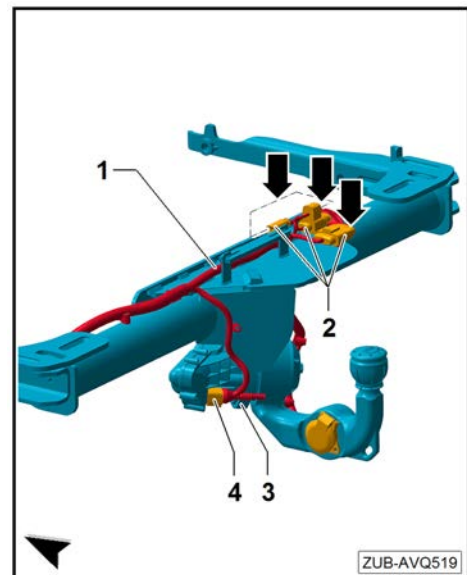

- Use the cable ties/retaining clips -1- to fasten the socket/electrical release retrofit wiring harness to the studs -2- on the cross member of the towing bracket.

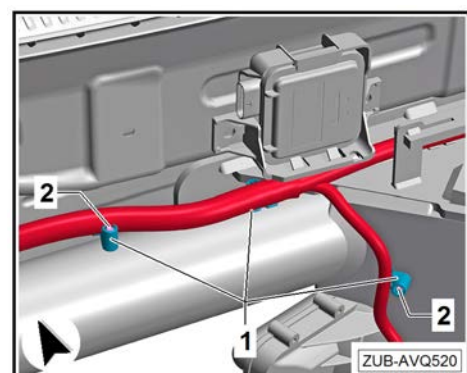



- Turn bolts -arrows- until they are slightly loose and press the heat shield -1- towards the towing bracket.

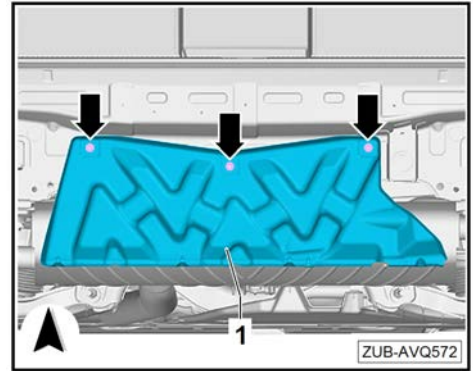

- Remove sealing cap -1- from the bottom opening in the body -in the direction of the arrow-.

**i Note**

*The cap -1- is no longer required once the towing bracket has been mounted.*

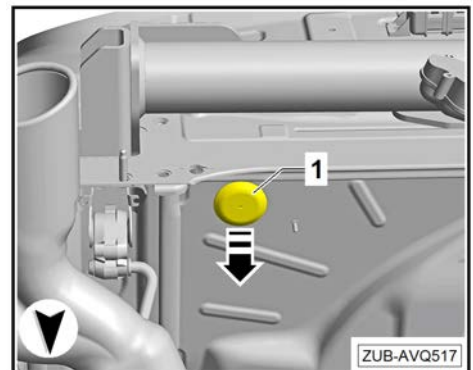

- Pull the socket/electrical release retrofit wiring harness -1- through the opening in the body and insert the sealing plug -3-.
- Route the socket/electrical release retrofit wiring harness -1- behind the convenience system central control unit -J393- towards the trailer detector control unit -J345-.

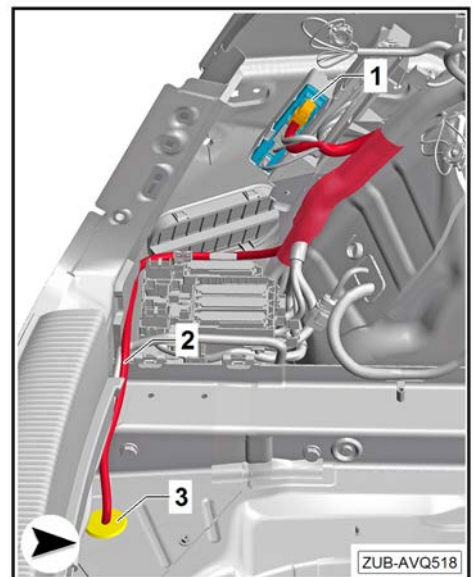

- Press heat shield -1- towards the cross panel, insert bolts -arrows- and tighten to a torque of 2.5 Nm.

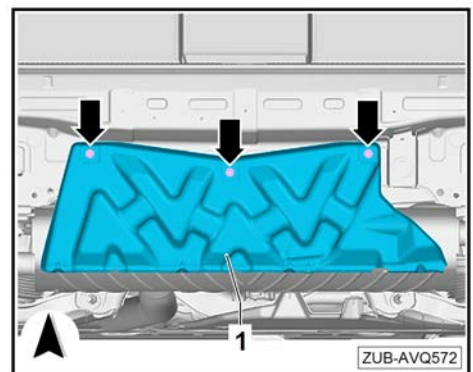



## 8.4 Connecting the onboard supply retrofit wiring harness

### Special tools and workshop equipment required

- ◆ Set of unpinning tools -VAS 1978/35-

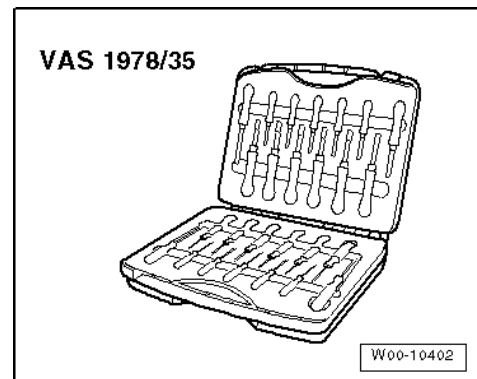

### 8.4.1 Pin assignment on the convenience system central control unit -J393-

1 - Convenience system  
central control unit  
-J393-

- A - 17-pin connector,  
brown
- B - 32-pin connector,  
black
- C - 17-pin connector,  
black
- D - 20-pin connector,  
black
- E - 32-pin connector,  
blue

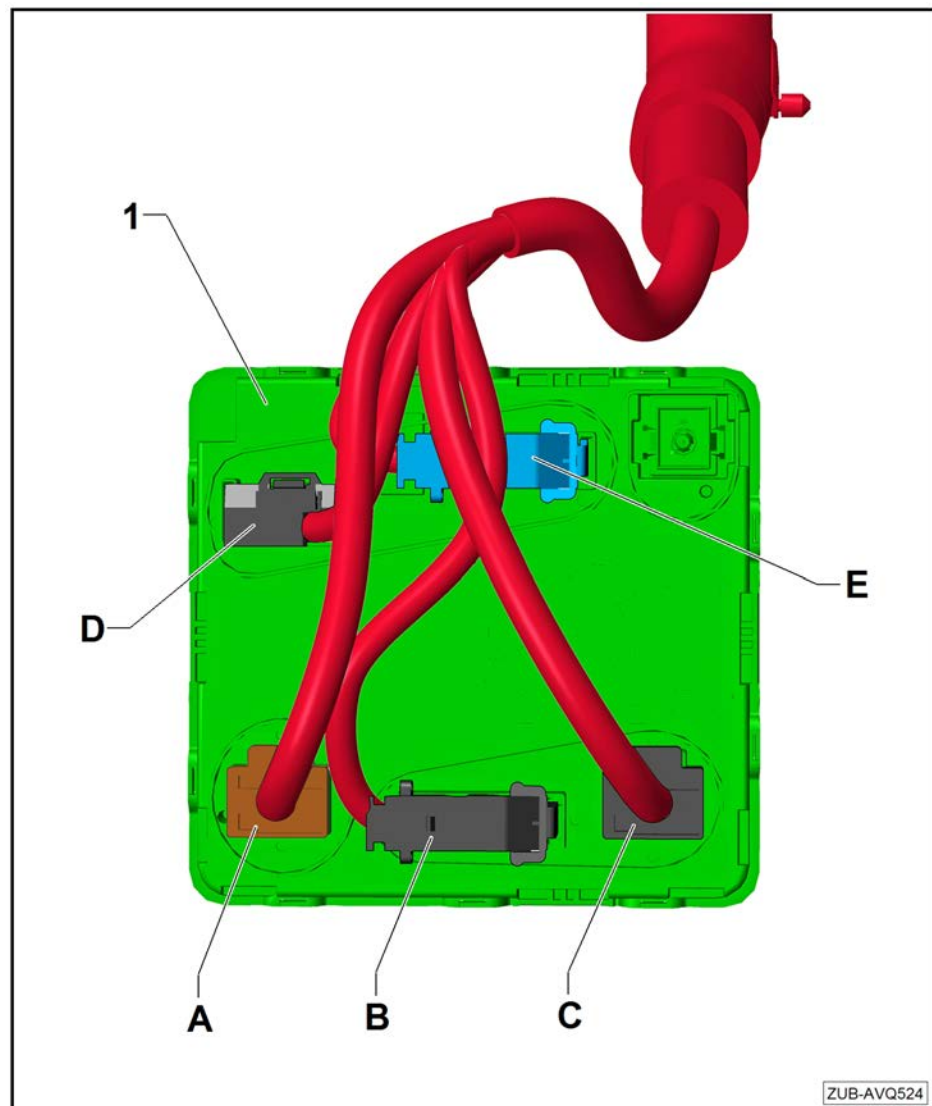



## 8.4.2 Integrating the CAN bus

- Release the blue connector -E- from the convenience system central control unit -J393- and disconnect.

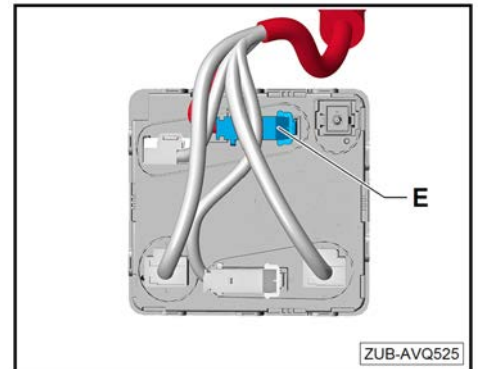

- Release the catches on the blue connector housing -arrows- and pull the connector block out of the connector housing.

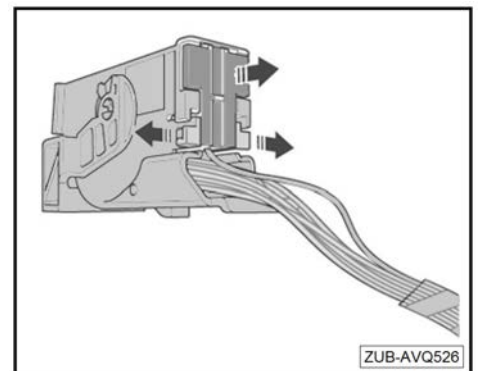

- Unpin contact from compartment -1- of the connector block.
- Unpin contact from compartment -2- of the connector block.

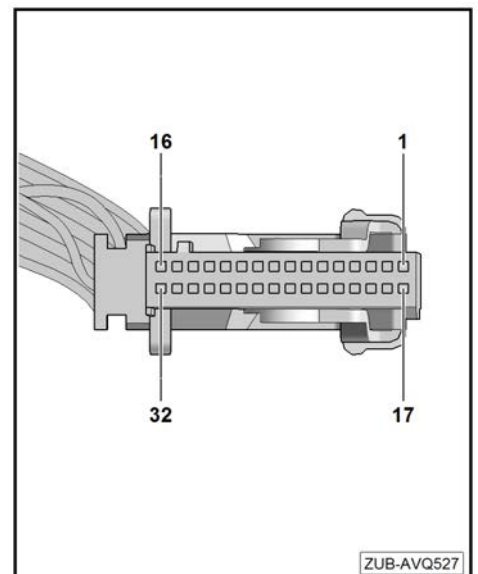



- Pin contact 1 of the connector block into compartment -1- of the included black socket housing -A- (3 chambers).
- Pin contact 2 of the connector block into compartment -3- of the included black socket housing -A- (3 chambers).

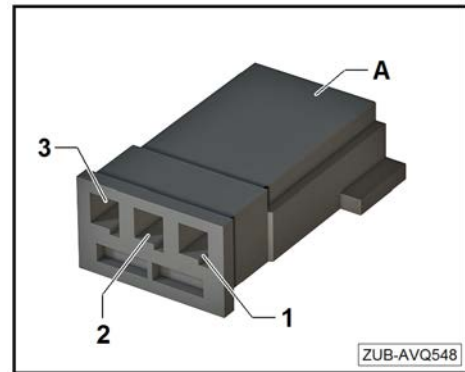

- Pin the corresponding contacts of the onboard supply retrofit wiring harness (Y-wires) into the compartments on the connector block.
- Pin the -orange/brown- wire of the retrofit wiring harness into compartment -1- of the connector block (CAN bus Low).
- Pin the -orange/green- wire of the retrofit wiring harness into compartment -2- of the connector block (CAN bus High).
- Insert the connector block into the blue connector housing and click into place.

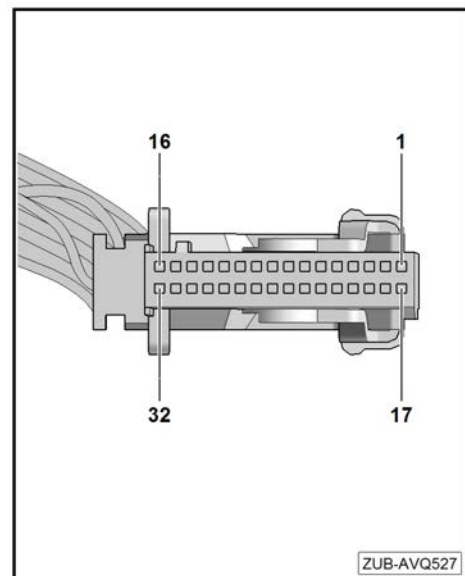

- Connect the socket housing (black) with the corresponding black connector on the onboard supply retrofit wiring harness -arrow-.

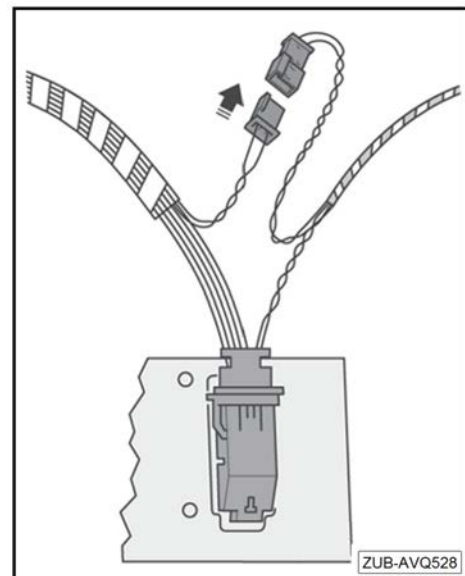



### 8.4.3 Connecting the brake light signal/terminal 15

- Release and disconnect the black, 32-pin connector -B- from the convenience system central control unit -J393-.

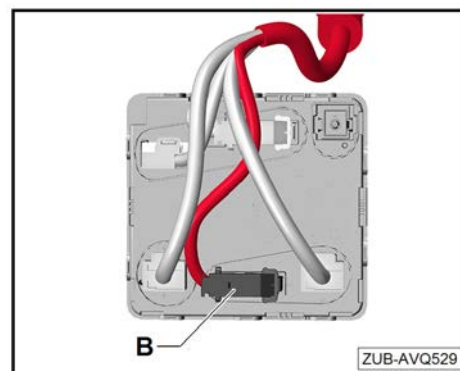

- Release the catches on the black connector housing -arrows- and pull the connector block out of the connector housing.

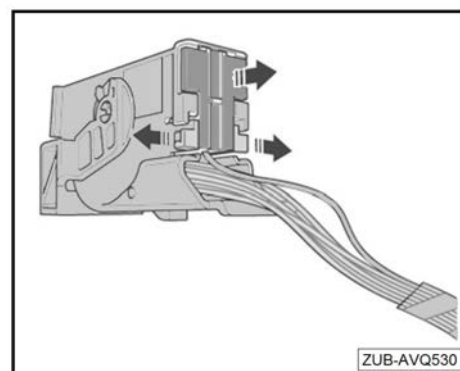

- Unpin contact from compartment -12- of the connector block.
- Unpin contact from compartment -17- of the connector block.

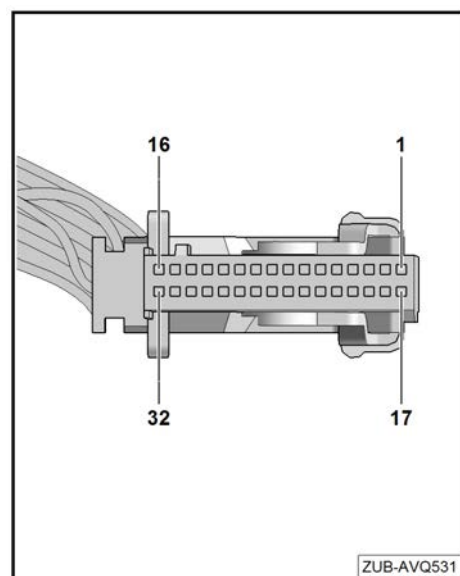



- Pin contact 12 of the connector block into compartment -3- of the included white socket housing -A- (3 chambers).
- Pin contact 17 of the connector block into compartment -1- of the included white socket housing -A- (3 chambers).

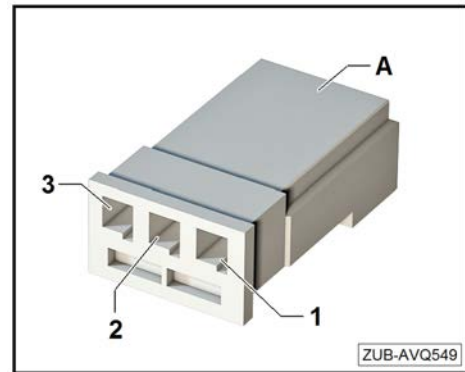

- Pin the corresponding contacts of the onboard supply retrofit wiring harness (Y-wires) into the compartments on the connector block.
- Pin the -black/red- wire from the -12-retrofit wiring harness into compartment of the connector block.
- Pin the -black- wire from the -17-retrofit wiring harness into compartment of the connector block.
- Insert the connector block into the black connector housing and click into place.

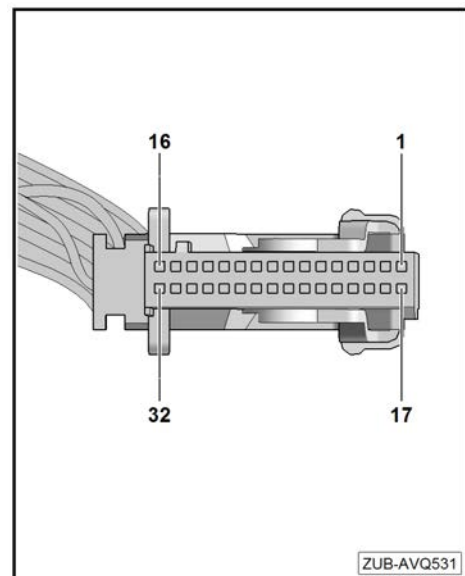

- Connect the socket housing (white) with the corresponding white connector on the onboard supply retrofit wiring harness -arrow-.
- Connect the black connector to the convenience system central control unit -J393- and lock.

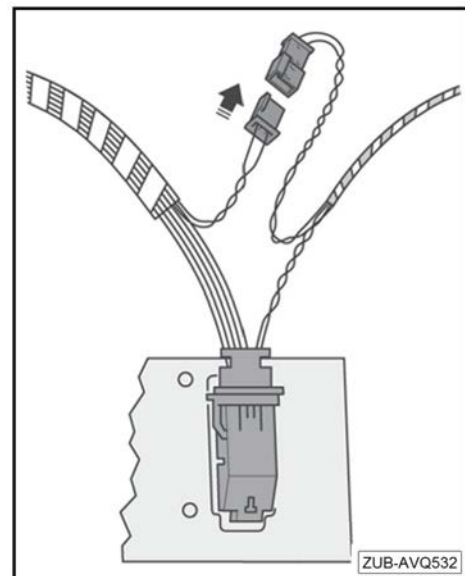



#### 8.4.4 Connecting the lighting for the electric swivelling towing bracket release button -E474- terminal 58s

- Release the brown connector -A- from the convenience system central control unit -J393- and disconnect.

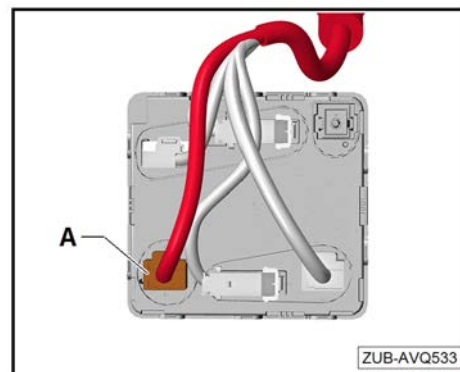

- Unlock the housing retaining clip on the brown connector housing and pull out -arrows-.

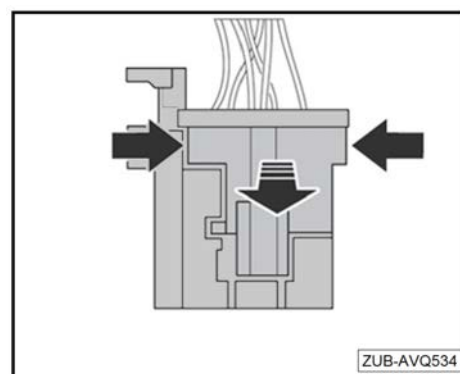

- Unpin contact from compartment -5- of the connector.

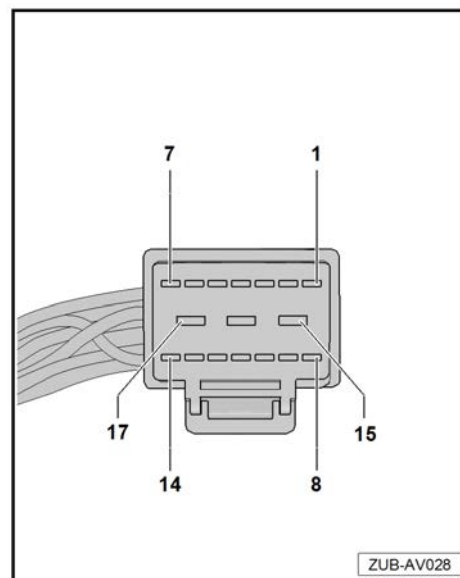



- Pin contact 5 of the connector block into compartment -1- of the included black socket housing -A- (2 chambers).

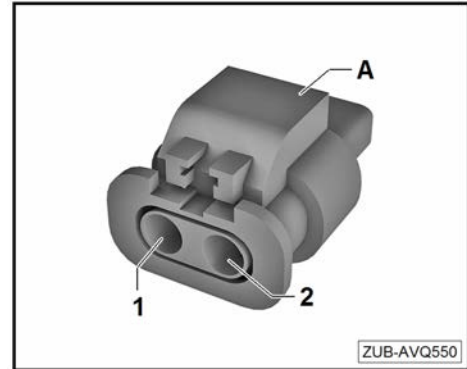

- Pin the corresponding contact of the onboard supply retrofit wiring harness (Y-wires) into the compartment of the connector housing.
- Pin the -yellow/black- wire of the -5-retrofit wiring harness into compartment .
- Push the housing retaining clip into the brown connector housing and lock.
- Insert the connector block into the black connector housing and lock.

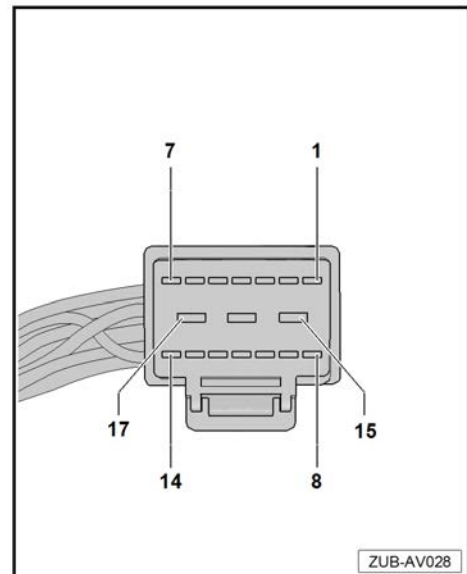

- Connect the socket housing (black, 2 compartments) with the corresponding black connector (2 compartments) on the onboard supply retrofit wiring harness -arrow-.
- Connect the black connector to the convenience system central control unit -J393- and lock.
- Secure the onboard supply retrofit wiring harness to the vehicle wiring harness using cable ties.
- The wires must be secured with cable ties in a manner that prevents slipping or abrasion.

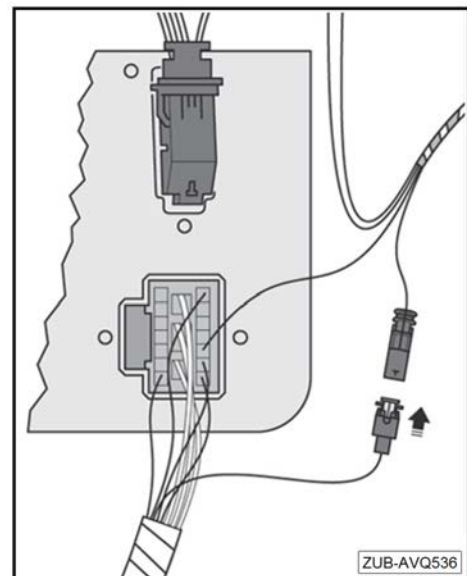



## 8.5 Establishing a power supply

- Release the retaining tab -arrow- and remove the fuse carrier ST5 in position -2- from the fuse holder -1- downwards -direction of arrow-.

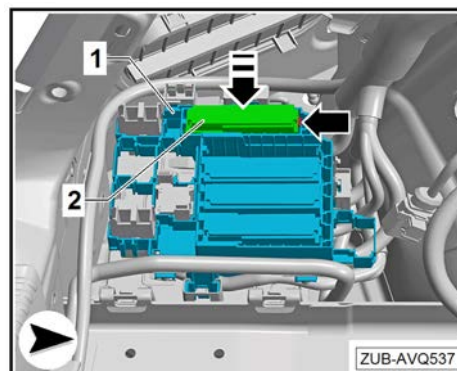

- Release the retaining clips -direction of arrows- and remove the cover from fuse carrier ST5.

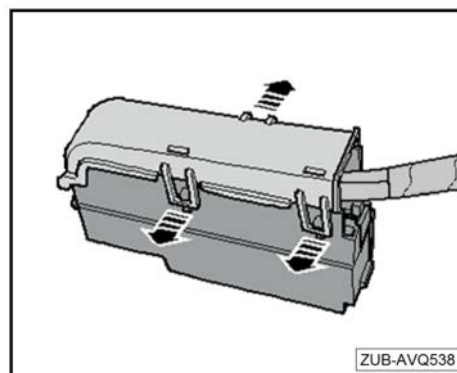

- Pull out the retaining strip -1- for the electrical connectors -in the direction of the arrow-.

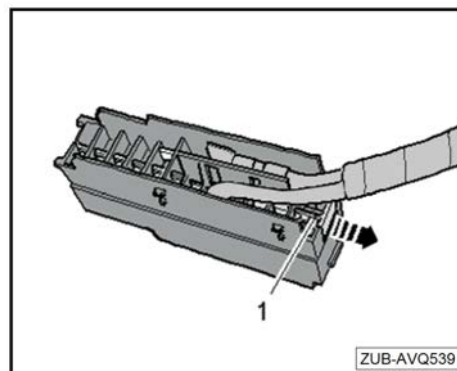

- Unlock the retainer from fuse carrier ST5 -arrows- and remove -direction of arrow-.

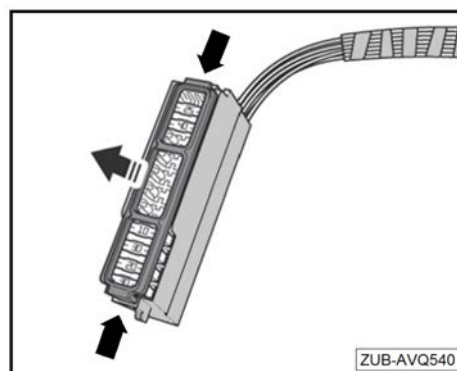



- Plug the onboard supply retrofit wiring harness contacts into fuse positions -5, 7, 8 and 9- on fuse carrier ST5.
- ◆ Compartment 9a: red wire
- ◆ Compartment 8a: red/blue wire
- ◆ Compartment 7a: red/green wire
- ◆ Compartment 5a: red/black wire



**WARNING**

**Compartment 6a must be kept empty – risk of errors in the vehicle electronics!**

- Insert the electrical connector retaining strip.
- Connect fuses 5, 7, 8 and 9.
- ◆ Fuse 9: 15 A
- ◆ Fuse 8: 25 A
- ◆ Fuse 7: 15 A
- ◆ Fuse 5: 25 A
- Install the retainer on fuse carrier ST5 and lock.
- Install the cover for fuse carrier ST5 and lock.
- Insert fuse carrier ST5 in position -2- into the relay and fuse holder F -1- and click into place.



**Note**

Route electrical wiring in such a way that the original wiring routing is restored.

## 8.6 Connecting the onboard supply retrofit wiring harness to the trailer detector control unit -J345-

- Connect electrical connectors --5-, -6- and -7- of the onboard supply retrofit wiring harness to the trailer detector control unit -J345- -1-.
- Connect all earth wires for the onboard supply retrofit wiring harness and the "socket/electrical release" retrofit wiring harness to the earth stud -2-.
- Tighten the nut for the earth stud -2- to torque.
- Route the onboard supply retrofit wiring harness -3- along the vehicle wiring harness and secure using cable ties.



**Note**

The wires must be secured with cable ties in a manner that prevents slipping or abrasion.

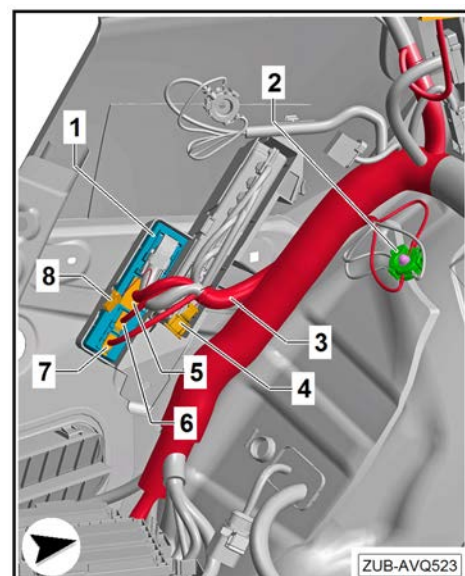
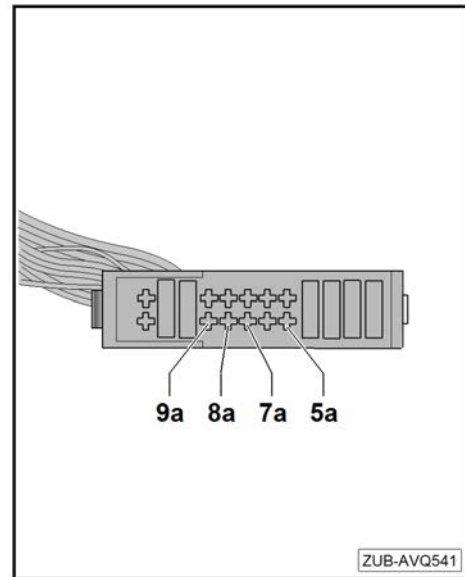



## 8.7 Adjusting the electrical connector for load sill lowering button -E539-

### Applies only to vehicles with load sill lowering

Unpin contacts 7, 10, 11 and 12 from the electrical connector for the electric swivelling towing bracket button -E474-. Next, pin the contacts into the respective compartments of the electrical connector for the load sill lowering button -E539-.

- Release the catch -1- of the electrical connector for the load sill lowering button -E539- on the vehicle wiring harness and pull out the housing retaining clip -2- to the side -arrow-.
- Release the catch -1- of the electrical connector for the electric swivelling towing bracket button -E474- on the onboard supply retrofit wiring harness and pull out the housing retaining clip -2- to the side -arrow-.

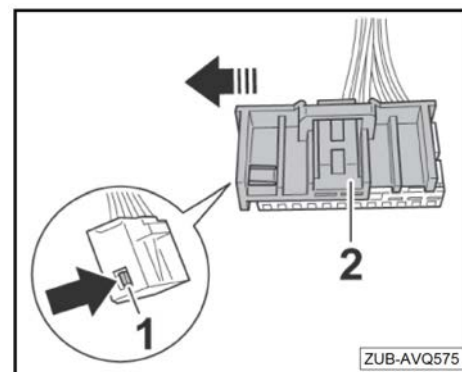

- Unpin the contacts from compartments 7, 10, 11 and 12 of the connector housing -1- electric swivelling towing bracket button -E474- on the onboard supply retrofit wiring harness.
- Pin the unpinned contacts into the respective compartments of the connector housing -2- load sill lowering button -E539- on the vehicle wiring harness.

- ◆ Compartment 7: yellow/green wire
- ◆ Compartment 10: yellow/white wire
- ◆ Compartment 11: yellow/brown wire
- ◆ Compartment 12: yellow/blue wire

#### Note

The contact in compartment 6 of the connector housing for the electric swivelling towing bracket button -E474- remains pinned in place.

- Insert the housing retaining clip on the connector housing of the electric swivelling towing bracket button -E474- and engage.
- Insert the housing retaining clip on the connector housing of the load sill lowering button -E539- and engage.

#### Note

Electrical connector -2- is no longer required.

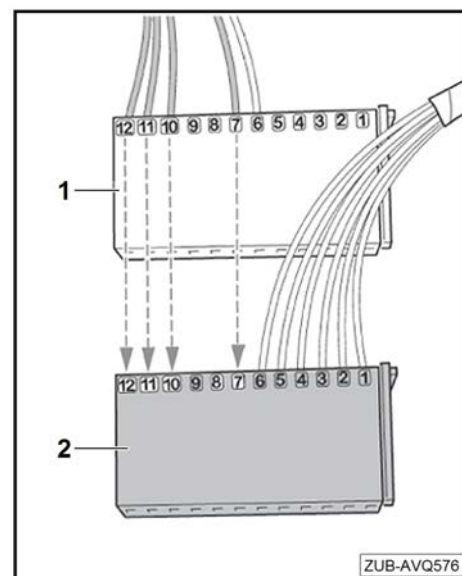



- Wrap the electrical connector -2- for the electric swivelling towing bracket button -E474- with fabric tape -1- to the vehicle's wiring harness for the electrical connector -3- load sill lowering button -E539- and fix in position.

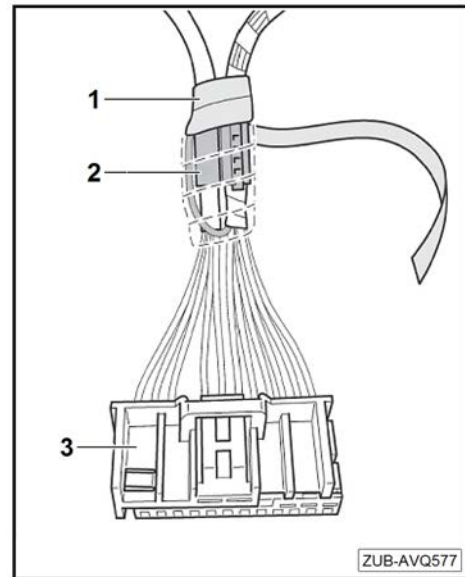

## 8.8 Installing the towing bracket electrical release button

### Note

- ◆ Depending on your equipment, the frame or the button for towing bracket electrical release must be replaced.
- ◆ Variant 1: Replace the frame with luggage hook -1- -image A- with the frame for the towing bracket electrical release button -2- -image B-.
- ◆ Variant 2: Replace the load sill lowering button -E539- with the towing bracket electrical release/load sill lowering button -3- -image B-.
- ◆ See "Overview of electrical system components" for details of the required button and button mount. → [Page 14](#)
- Insert the towing bracket electrical release/load sill lowering button in the button mount and clip in place.
- Insert the button mount and button into the luggage compartment left-hand side trim and clip in place.

### Note

The electrical connector on the button is plugged in during installation in the luggage compartment side trim.

- Plug in the electrical connector on the button.
- When installing the luggage compartment side trim, route electrical wiring in a manner that prevents the wires from being abraded or trapped.

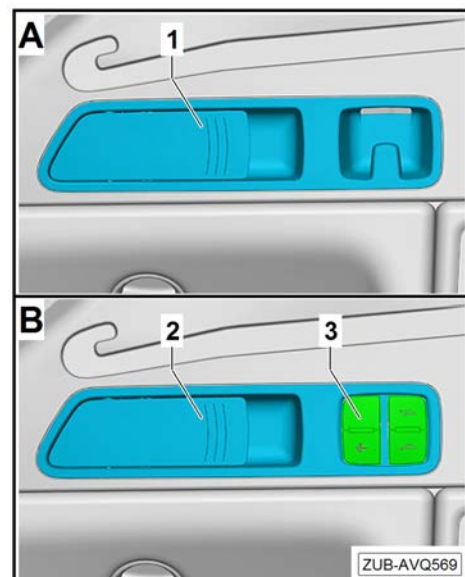



## 9 Concluding operations

### 9.1 Reassembling the vehicle

To install the components, follow the removal steps in reverse order. Observe the "Notes on installation" for the relevant components and the corresponding tightening torques.

#### **WARNING**

*The following information must be observed when working with the lane change assist (Audi side assist):*

- ◆ *If the rear bumper cover is removed and then reinstalled, or if any modifications are made to the rear bumper cover, the lane change assist system (Audi side assist) must be recalibrated ⇒Electrical system; Rep. gr. 96; Risk of accident due to malfunction!*

### 9.2 Connecting the battery

- Connect the battery⇒Electrical system; Rep. gr. 27; Battery; Disconnecting and connecting the battery

#### **Note**

*After reconnecting the power supply, the ESP warning light can only extinguish after a few metres have been driven.*

### 9.3 Adapting the trailer detector control unit -J345- coding

Coding is adjusted using the ⇒ Vehicle diagnostic tester. This must be connected online.

#### **WARNING**

*Before you start the activation process, go into the self-diagnosis function and check that it is possible to contact the DA69 (towing bracket control unit); this ensures that the CAN bus is connected. Cross reference error: reference link ID='X-6STRX0668AD' not found*

*Enter the "clear error" (Fehler löschen) command for the DA69 in the self-diagnosis function; by doing so, you can identify whether all power supplies and the earth are present; if the result is positive, you can continue; if the result is negative, check all power supplies as well as the fuse and contacts!*

*If this is not done, you will receive result code FFP0707E.*

### 9.4 Commissioning and functional check

- Check that the trailer socket -U10- functions correctly using the trailer socket tester -VAS 5800- or a trailer.



### Pin assignment in the trailer socket -U10-

- 1 - Terminal LTS (left turn signal)
- 2 - Terminal RFL (rear fog light)
- 3 - Terminal 31 (earth) earth for terminals 1–2, 4–8
- 4 - Terminal RTS (right turn signal)
- 5 - Terminal 58 R (right tail light)
- 6 - Terminal 54 (brake light)
- 7 - Terminal 58 L (left tail light)
- 8 - Terminal RVL (reversing light)
- 9 - Terminal 30 (battery "+") max. current 15 A
- 10 - Terminal 15 (charging cable) max. current 15 A
- 11 - Terminal 31 (earth) earth for terminal 10
- 12 - Not assigned
- 13 - Terminal 31 (earth) earth for terminal 9

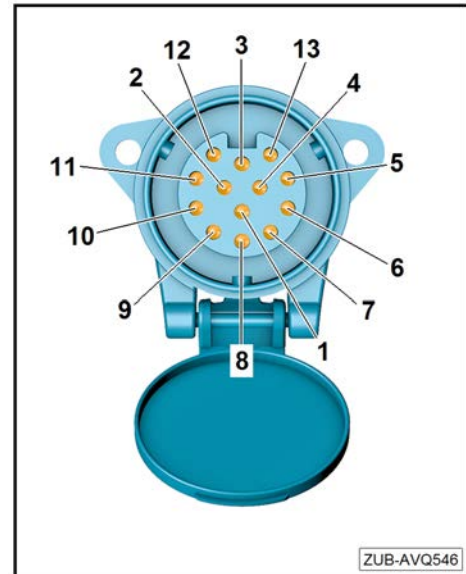

### 9.5 Attach the information sticker

- Clean the bonding surfaces and affix the “Towing with towing bracket” -1- and “Trailer drawbar load” -2- stickers to the inner left of the D-pillar.

#### Note

The bonding surfaces must be free of dust and grease!

#### **WARNING**

Once assembled, check the towing bracket functions correctly ⇒ Owner's Manual.

#### Note

Keep these assembly instructions with the vehicle documents so that they can be presented to authorised persons upon request.

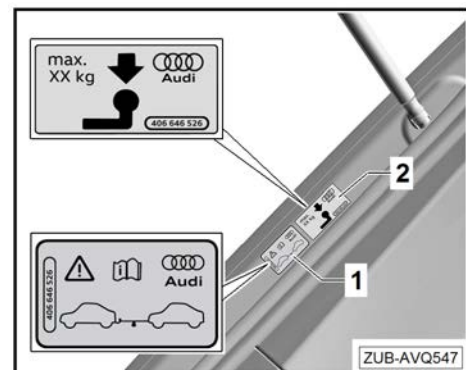

### 9.6 Adjusting the cooling system

As towing mode puts greater demands on the engine cooling system, the cooling system is upgraded – where technically possible – when the towing bracket is installed in the factory.

The cooling system does not need to be upgraded if it is possible to guarantee that the engine is only ever exposed to the following conditions:

- ◆ The permissible gross combination weight is underrun
- ◆ No high ambient temperatures
- ◆ No long, steep inclines
- ◆ No high altitude journeys



In any case, the coolant temperature display must be carefully monitored. If the display moves into the hot area, the speed must be reduced immediately. A cool-down time must also be allowed for if necessary. This involves the allowing the engine to idle for approx. 2 minutes to prevent a build-up of heat.