

Fitting instructions

Q6 e-tron 2024 ►

Q6 Sportback e-tron 2024 ►

**Fixed/mechanically removable trailer hitch with
electrics set (NAR),
for package number 85H.092.115.*
Audi Genuine Accessories**

Edition 01



Contents

1	General Notes	1
2	Safety instructions for pyrotechnical, electrical and mechanical components of the restraint system	2
2.1	General safety instructions	2
2.2	Storing, transporting and disposing of airbag, belt tensioner and battery cut-out elements (pyrotechnic components)	3
3	Safety notes on the trailer hitch – Fitting and operation	4
3.1	Notes on the towing vehicle	4
3.2	Notes on the Trailer Hitch	4
3.3	Safety Notes on Assembly	5
3.4	Safety Notes on Operation	5
4	Overview of Components	6
4.1	Overview of Mechanical Components	6
4.2	Overview of Electrical System Components	7
4.3	Additional required parts	7
5	Preparatory Work	8
5.1	Disconnecting the Battery	9
5.2	Remove the following components	9
6	Assembly overviews and tightening torques	11
6.1	Towing bracket with cross member	11
7	Fitting the Towing Bracket	12
7.1	Installing the Socket	12
7.2	Fitting the Towing Bracket	12
8	Electrical Connection	14
8.1	Installing the Towing Recognition Control Module J345	14
8.2	Connecting the trailer hitch connector for the socket/electrical release to towing recognition control module J345	14
8.3	Installing the vehicle electrical system retrofit wiring harness	15
8.4	Installing the “CAN” retrofit wiring harness	15
8.5	Inserting the fuses into the relay and fuse panel	17
8.6	Connecting the Supply Line for the Brake Booster	18
8.7	Connecting the CAN Bus	18
9	Final Tasks	19
9.1	Reassembling the Vehicle	19
9.2	Connecting the Battery	19
9.3	Adapting the towing recognition control module -J345- activation process	19
9.4	Functional Check on the Socket	19



9.5	Reassembling the Vehicle	20
-----	--------------------------------	----





1 General Notes

Please read these instructions carefully and note the Danger, Warning, Caution, Note and TIP descriptions before the "trailer hitch" is installed.

DANGER

Text with this symbol indicates dangerous situations where a failure to comply could result in death or serious injuries.

WARNING

Text with this symbol indicates dangerous situations where a failure to comply could result in death or serious injuries.

CAUTION

Text with this symbol indicates dangerous situations where a failure to comply could result in minor or moderate injuries.

NOTICE

Text with this symbol indicates situations where a failure to comply could result in damage to the vehicle.

TIP:

Text with this symbol contains important additional information.

NOTICE

For safety reasons, the trailer hitch must only be fitted by skilled personnel – risk of accident!
Additional modifications may be required – risk of accident. Detailed information can be found in these installation instructions.

The pages that follow contain all of the information (subject to technical change) required to install and remove the trailer hitch used on the vehicle.

AUDI AG will not accept responsibility in the event of failure to comply with these assembly instructions.



2 Safety instructions for pyrotechnical, electrical and mechanical components of the restraint system

2.1 General safety instructions

Pyrotechnical components comprise:

- ◆ Airbag units
- ◆ Belt tensioners
- ◆ Belt force limiters
- ◆ Battery cut-out elements

General

- ◆ Testing, installation and maintenance tasks must only be carried out by trained personnel.
- ◆ There are no replacement intervals for airbag units.
- ◆ Do not check using circuit tester, voltmeter, or ohmmeter under any circumstances.
- ◆ Pyrotechnic components must only be checked when installed and using ⇒ vehicle diagnostic testers that have been approved by the manufacturer.
- ◆ When working on pyrotechnic components and on the airbag control module -J234-, the battery earth wire must be disconnected when the IGNITION is SWITCHED ON. The battery negative terminal must subsequently be covered.
- ◆ You must wait ten seconds after the battery -A- has been disconnected.
- ◆ The battery -A- must be connected when the IGNITION is SWITCHED ON. There must not be anybody inside the vehicle during this process. Exception: vehicles with battery -A- located inside the vehicle. Do not sit within the airbag and seat belt deployment range during this process.
- ◆ Observe the appropriate steps after connecting the battery ⇒ [Page 19](#).
- ◆ Before performing any work on pyrotechnic components in the restraint system, e.g. before disconnecting the electrical connector, the mechanic carrying out the task must discharge any static electricity. Electrostatic discharging can be performed by touching earthed metal parts, e.g. by briefly touching the door striker plate.
- ◆ Wash hands after touching ignited pyrotechnical components of the restraint system.
- ◆ Pyrotechnical components must neither be opened nor repaired. New parts must always be used (risk of injury).
- ◆ Pyrotechnic components that have fallen onto a hard surface or that show any sign of damage must not be installed.



- ◆ Pyrotechnic components must be installed immediately after they are removed from the transport container.
- ◆ If work is interrupted, the pyrotechnic component must be returned to the transport container.
- ◆ Pyrotechnic components must not be left unattended.
- ◆ When connecting the pyrotechnic components in the restraint system, only the person performing the work may be in the interior of the vehicle.
- ◆ Pyrotechnic components must not be treated with grease, cleaning agents or similar products.
- ◆ If the fabric becomes contaminated with substances such as oil, grease, paint, color or solvents, the airbag unit must be replaced.
- ◆ In addition, pyrotechnic components must not be exposed to temperatures above 100 °C, even for short periods.

2.2 Storing, transporting and disposing of airbag, belt tensioner and battery cut-out elements (pyrotechnic components)

- ◆ Storage is subject to the applicable national legislation.
- ◆ Transportation is subject to national and international laws governing packaging, naming, labeling and accompanying documentation.
- ◆ Pyrotechnic components that have not been ignited must be returned in the original packaging for appropriate recycling in line with the applicable national legislation! Contact your importer if you have any questions.
- ◆ Only pyrotechnic components that have been completely ignited may be disposed of as industrial waste.

CAUTION

This does not apply to belt tensioners that operate according to the Wankel tensioner principle. Tensioners of this kind should be handled in the same way as pyrotechnic components that have not been ignited (e.g. airbags).

Background: For belt tensioners that operate according to the Wankel tensioner principle, it is not possible to check whether all ignition stages have completed using workshop tools.



3 Safety notes on the trailer hitch – Fitting and operation

3.1 Notes on the towing vehicle

Manufacturer: AUDI AG
Model: Q6 e-tron 2024 ►, Q6 Sportback e-tron 2024 ►
Offic. type designation: GF

Maximum trailer weight or trailer drawbar load in kg, as specified by the manufacturer for the above-named vehicle model: ⇒
Vehicle registration certificate/Owner's Manual.

3.2 Notes on the Trailer Hitch

Technical Data	Vehicles with steel-spring suspension/air suspension
Audi part no.:	95C.803.881.*

TIP:

The drawbar load figures specified on the type plate of the trailer hitch are test values only. Vehicle-specific figures are often lower than these values and can be found in the vehicle documents.

Please see your vehicle documents for your maximum trailer weight.

NOTICE

Do not exceed the verified D-value and the permitted trailer drawbar load – risk of accident!

The trailer hitch is intended for towing trailers fitted with a tow ball and for operating carriers suitable for mounting to the coupling ball.

The nationally applicable regulations must be adhered to in EU and non-EU countries.

Improper use is prohibited.

Use is only permitted under favorable road conditions and must be adapted to road conditions.



3.3 Safety Notes on Assembly

! NOTICE

For safety reasons, the trailer hitch must only be fitted by skilled personnel – risk of accident!

- ◆ **If replacement parts are required, these must only be installed by skilled personnel and to undamaged genuine parts – risk of accident!**
- ◆ **Installation must be in line with AUDI AG/Volkswagen AG guidelines – risk of accident!**
- ◆ **It is not permitted to modify the towing bracket. This will invalidate the type approval – risk of accident and legal implications!**
- ◆ **Use of the mounting points approved as standard by the vehicle manufacturer is mandatory – risk of accident!**

- Remove underbody sealing, body cavity sealant (wax) or insulation material from the area around the contact surfaces of the trailer hitch with the vehicle.
- In order to provide adequate corrosion protection to bare metal body parts, use a brush to apply the following products:
 - ◆ Single-component primer surfacer LGF.008.001.42/43
 - ◆ Two-component HS vario surfacer LGF.786.004.A4
 - ◆ Paint to match the vehicle color
 - ◆ Body cavity preserving agent D.330.KD2.A1

3.4 Safety Notes on Operation

! NOTICE

Vehicle handling is affected by the use of trailer mode; increased driver awareness is required – risk of accident!

- ◆ **Read the notes in the “Trailer mode” chapter of the ⇒ Owner’s Manual – risk of accident!**



4 Overview of Components

4.1 Overview of Mechanical Components

1 - Towing bracket with cross member

□ 1x

2 - Trailer hitch mounting nuts

- M12 x 1.5
- 50 Nm + 90°
- 8x

3 - Cover

□ 1x

4 - "Type plate" sticker

□ 1x

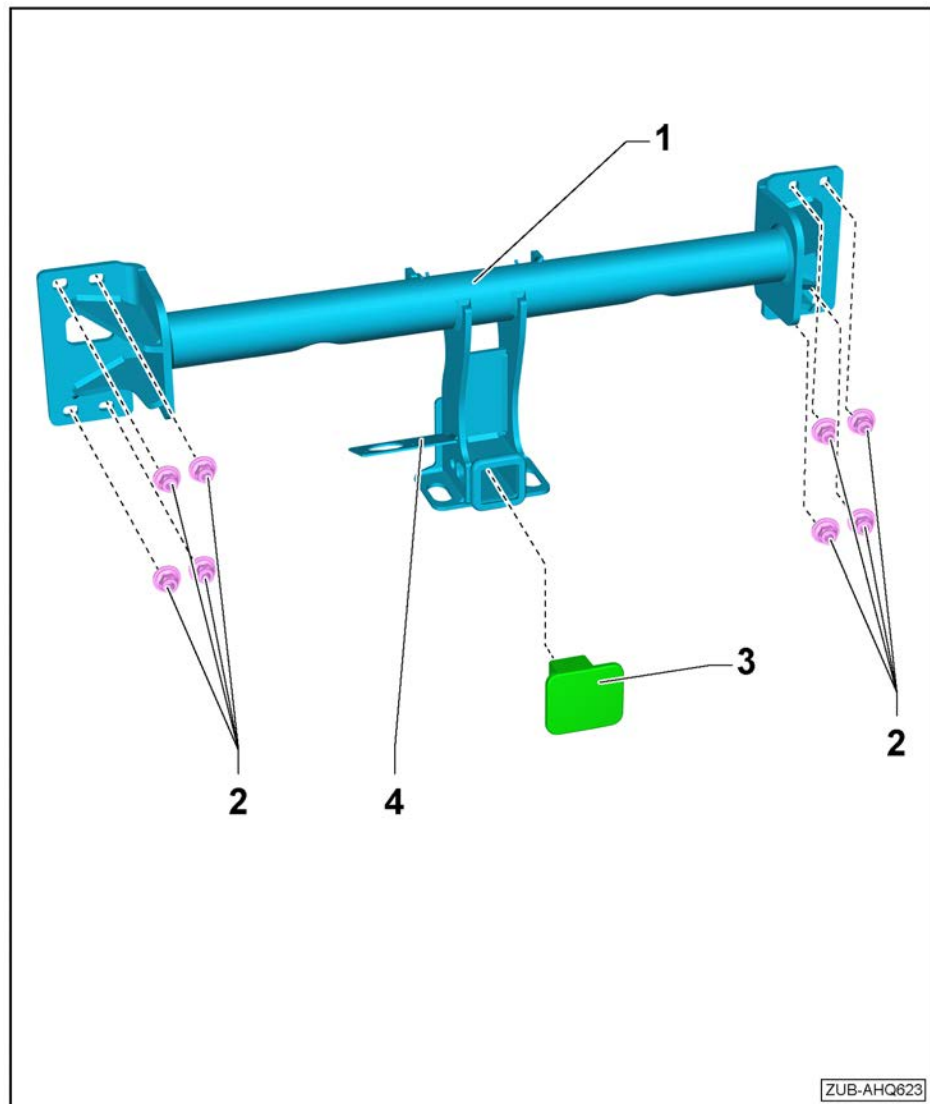

i Note

The ball mount is not included in delivery of the trailer hitch.



4.2 Overview of Electrical System Components

- 1 - Retrofit electrical socket wiring harness**
 1x
- 2 - Socket**
 7-pin
 1x
- 3 - Securing bolt for the socket**
 4x
 2.5 Nm
- 4 - Cable tie for tucker bolts**
 5x short
- 5 - Towing recognition control module -J345-**
 1x
- 6 - Information sheet**
 1x
- 7 - Activation document**
 1x
- 8 - 15-A fuse**
 1x
- 9 - 25-A fuse**
 2x
- 10 - 20 A fuse**
 1x
- 11 - Cable ties**
 3x

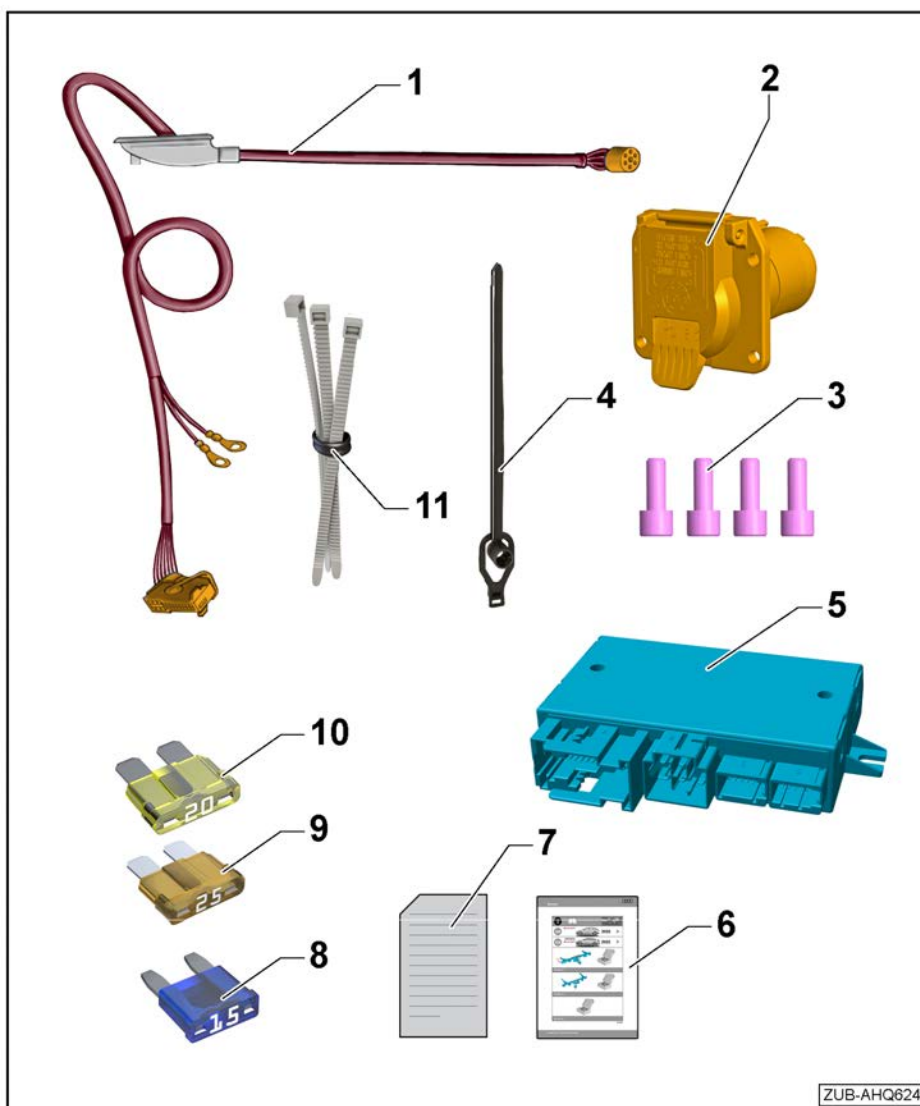

4.3 Additional required parts

Wiring harness 85H.055.307 ⇒ Electronic parts catalogue order as required. See ⇒ [Page 15](#)

Bracket 85H.907.392.* -1- ⇒ Electronic parts catalogue order.

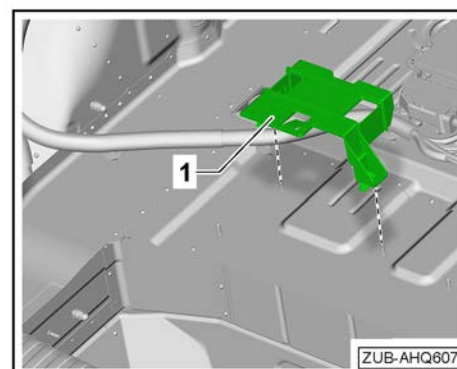



5 Preparatory Work

Required special tools, testing instruments, measuring instruments and auxiliary devices

- ◆ Torque wrench -V.A.G 1410-

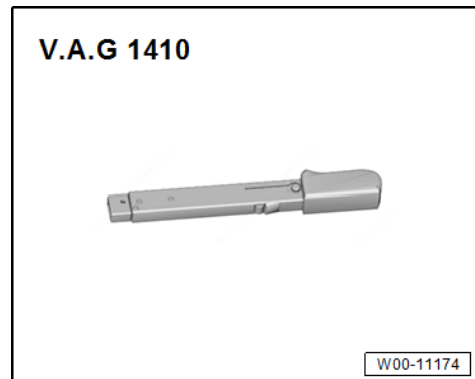

- ◆ Torque wrench -V.A.G 1332-

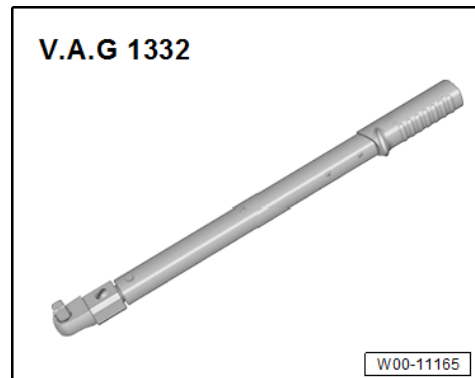

- ◆ Removal lever -80 - 200-

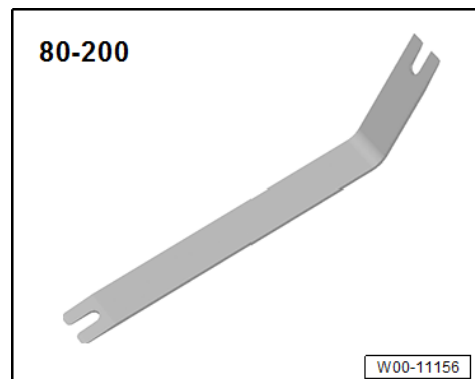

- ◆ Wedge -3409-

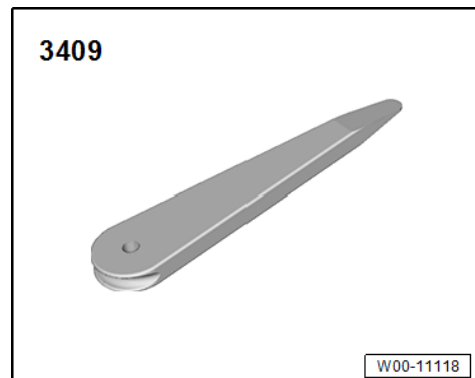



5.1 Disconnecting the Battery

Disconnect the battery ⇒ Electrical system; Rep. Gr. 27; Battery; Disconnecting and connecting the battery

! NOTICE

- ◆ Always make sure that the vehicle's electrical system is protected by disconnecting the battery before performing work on the electrical system.
- ◆ Only unscrew the battery negative terminal (-) of the battery.
- ◆ The battery positive terminal (+) of the battery must only be unscrewed once the battery has been removed from the vehicle.

5.2 Remove the following components

Remove the rear shelf ⇒ General body repairs, interior; Rep. Gr. 70; Interior trims; Removing and installing the rear shelf

Remove the luggage compartment floor mat ⇒ General body repairs, interior; Rep. Gr. 70; Luggage compartment trims; Removing and installing the luggage compartment floor

Remove the fastening rings ⇒ General body repairs, interior; Rep. Gr. 70; Luggage compartment trims; Removing and installing the fastening rings

Assembly overview of bench seat ⇒ General body repairs, interior; Rep. Gr. 72; Rear seat; Assembly overview — bench seat/individual seats

Remove the bench seat ⇒ General body repairs, interior; Rep. Gr. 72; Rear seats; Installing and removing the bench seat/individual seats

Remove the rear seat backrest ⇒ General body repairs, interior; Rep. Gr. 72; Rear seats; Installing and removing the rear seat backrest

Remove the rear lid lock trim ⇒ General body repairs, interior; Rep. Gr. 70; Luggage compartment trim; Removing and installing the rear lid lock trim

Assembly overview of luggage compartment side trim ⇒ General body repairs, interior; Rep. Gr. 70; Luggage compartment trims; Assembly overview of luggage compartment side trim

Remove the left-hand support for luggage compartment floor ⇒ General body repairs, interior; Rep. Gr. 70; Luggage compartment trims; Removing and installing the support for the luggage compartment floor

Remove the left-hand luggage compartment side trim ⇒ General body repairs, interior; Rep. Gr. 70; Luggage com-



partment trims; Removing and installing the luggage compartment side trim

Remove rear bumper cover ⇒ General body repairs, exterior; Rep. Gr. 63; Rear bumper; Removing and installing the bumper

Remove the impact bar ⇒ General body repairs, exterior; Rep. Gr. 63; Rear bumper; Removing and installing the impact bar



6 Assembly overviews and tightening torques

6.1 Towing bracket with cross member

1 - Towing bracket with cross member

- Fitting

2 - Trailer hitch mounting nuts

- M12 x 1.5
- 50 Nm + 90°
- 8x

3 - Cover

- 1x

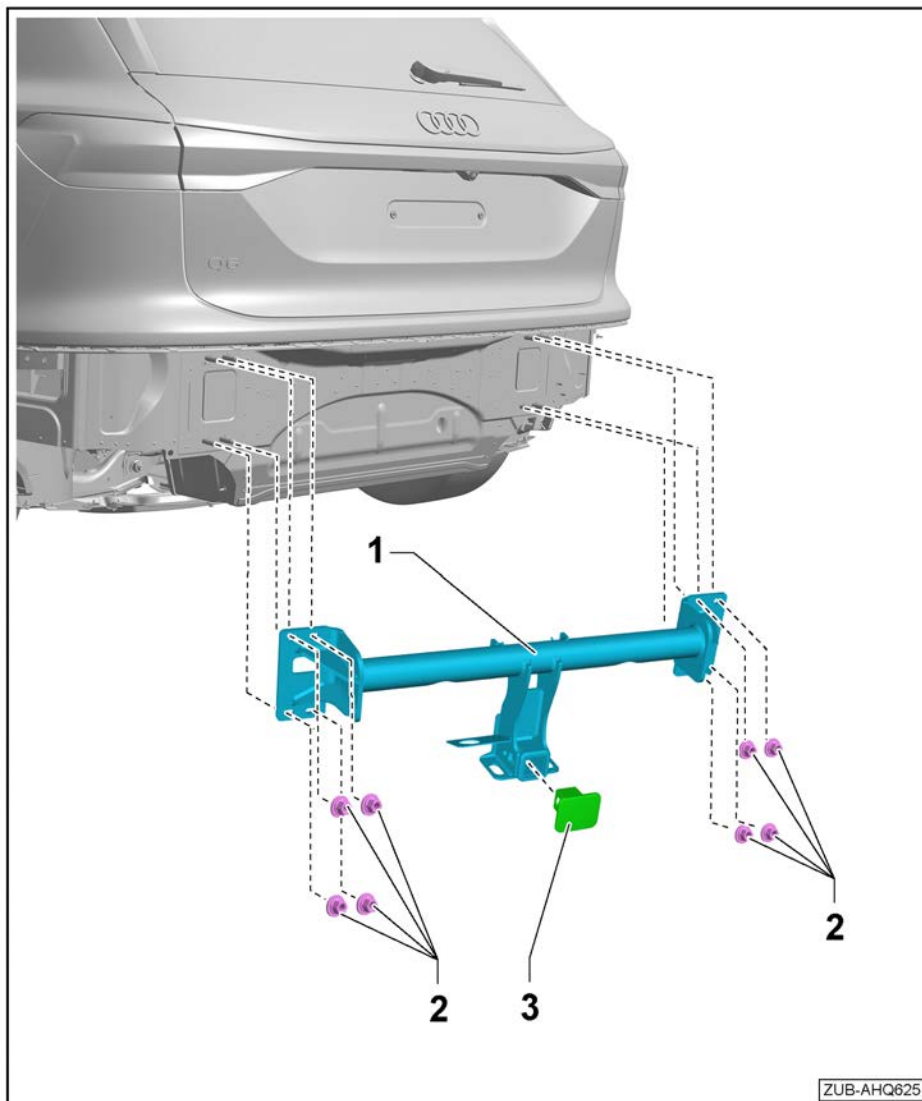



7 Fitting the Towing Bracket

7.1 Installing the Socket

- Connect the trailer socket -2- to the electrical connector -1-.

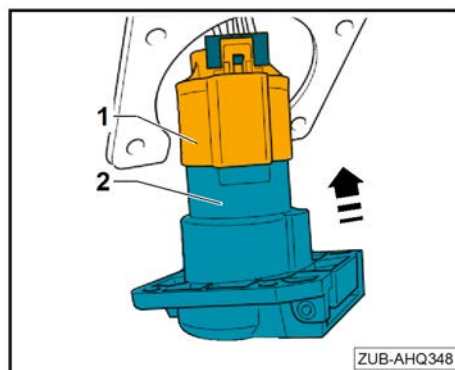

- Press in the locking element -1- for the electrical connector in -the direction of the arrow-.

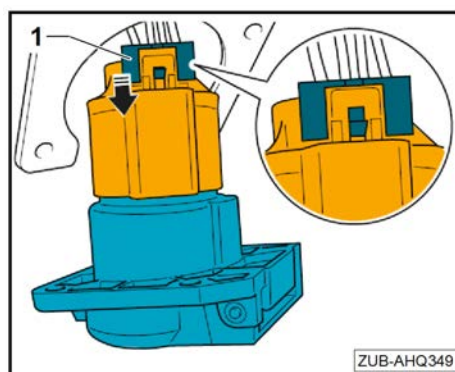

- Insert the trailer socket -3- in the bracket -1-.
- Insert bolts -2- and tighten to a tightening torque of 2 Nm.

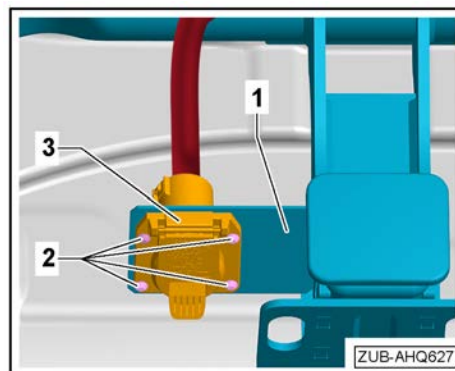

7.2 Fitting the Towing Bracket

- Remove sealing plugs -4-.

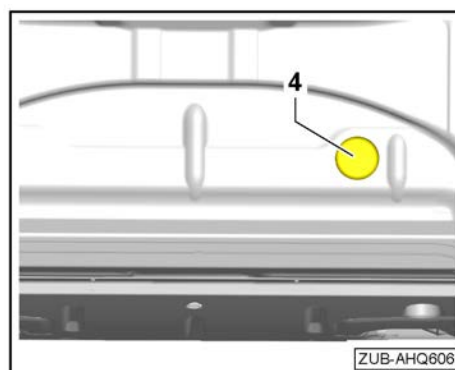



- With the help of a second mechanic, insert the trailer coupling with cross member -1- into the ends of the frame.
- Screw on the left and right bolts -2- for securing the trailer hitch -1- and tighten to the required torque ⇒ [Page 11](#).
- Feed the socket retrofit wiring harness -3- for the towing recognition control module -J345- through the opening and insert the grommet -4-.

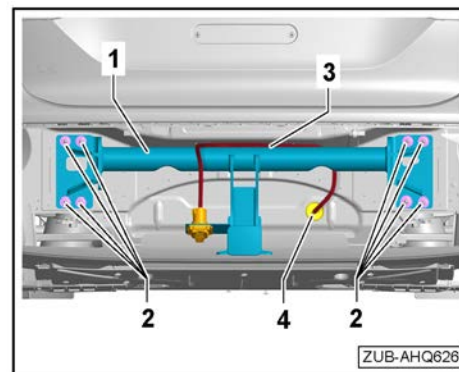

- Secure the socket retrofit wiring harness -3- to the trailer hitch -1- using cable ties -2- for tucker bolts.

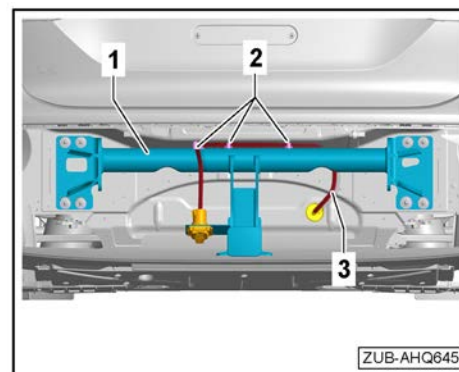



8 Electrical Connection

8.1 Installing the Towing Recognition Control Module J345

The towing recognition control module -J345- must be installed on all vehicles.

Preparatory work

- ◆ The battery has been disconnected.
- Attach the towing recognition control module -J345- -1- bracket until it snaps into place.
- Clip the towing recognition control module -J345- -2- into the bracket -1-.

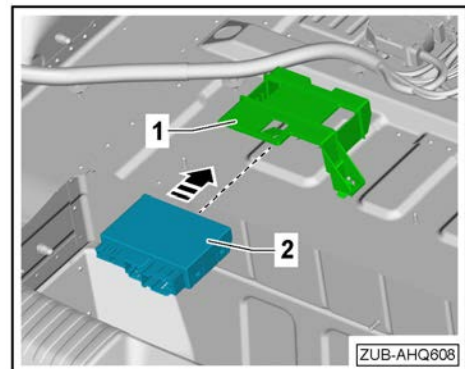
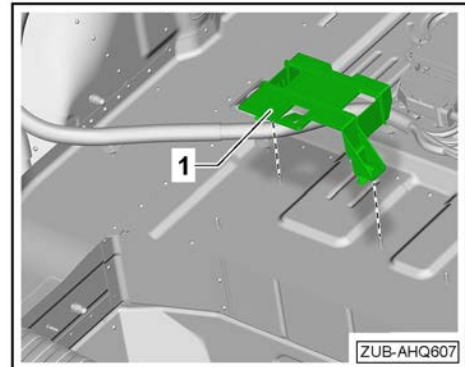

8.2 Connecting the trailer hitch connector for the socket/electrical release to towing recognition control module J345

- Connect the trailer hitch connector for the socket/electrical release -3- into the towing recognition control module -J345- -2- and fasten using the white bracket.

TIP:

Fix any excess wire lengths in position with a cable tie to prevent noise.

- Establish the earth connection -7-.

Notes on further installation

Earth point tightening torque: 9 Nm

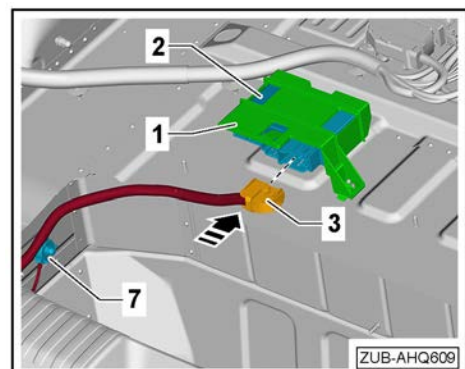



8.3 Installing the vehicle electrical system retrofit wiring harness

TIP:

For vehicles with preparation 1D8, connectors -4 and 5- on the preparation wiring harness must be connected.

- Connect connectors -4 and 5-.

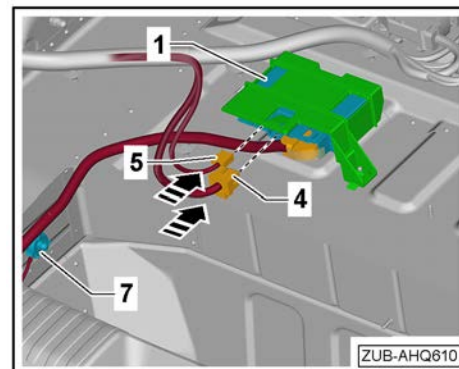

8.4 Installing the “CAN” retrofit wiring harness

Applies to vehicles up to construction period including CW25/2024:

Additional components required, not included in the scope of delivery, to be ordered in ETKA:

Wiring harness 85H.055.307

- Remove the connector -5- from the trailer control module.

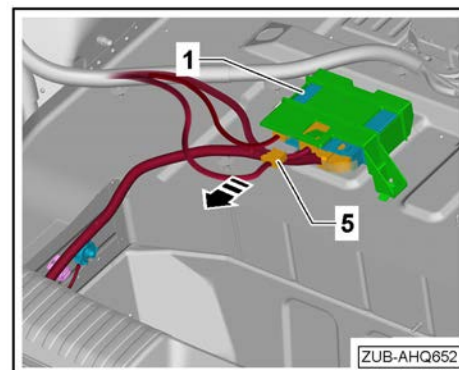

- Pin the following wires into the connector -5-

Green cable (CAN-High) into slot 3

Orange/brown cable (CAN-Low) into slot 4

- Route the wiring harness to the comfort system central control module -J393-, fix it with cable ties and secure it against noise.

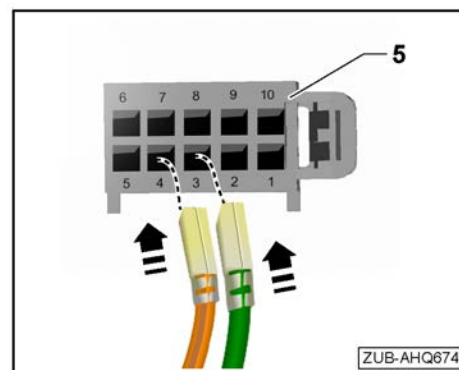



The CAN bus is connected to the comfort system central control module -J393- (connector A).

- Release and disconnect connector A on the comfort system central control module -J393--1-.

Open the connector housing and unpin the following cables.

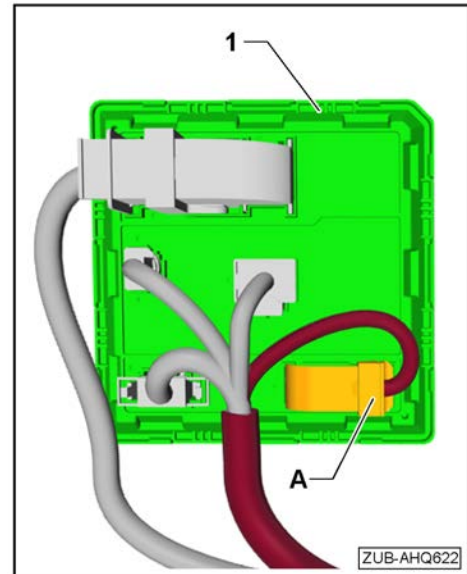

- ◆ Pin 51: CAN bus low, orange/brown

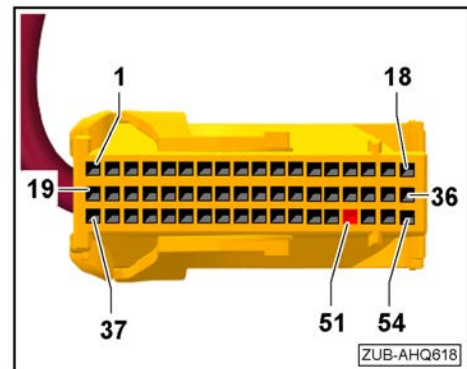

- ◆ Pin 52: CAN bus High, green

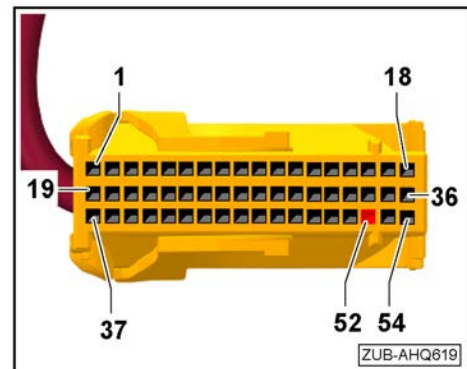

- Pin the CAN bus Low orange/brown cable from the retrofit wiring harness.

- ◆ Pin 51

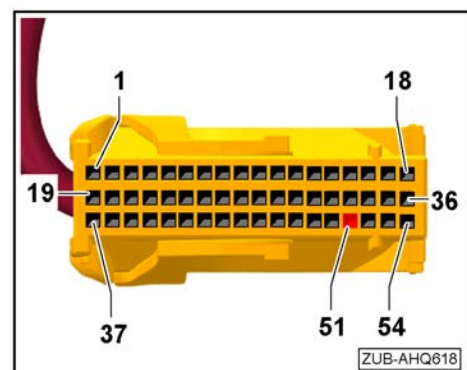



- Pin the CAN bus High green cable from the retrofit wiring harness.
- ◆ Pin 52

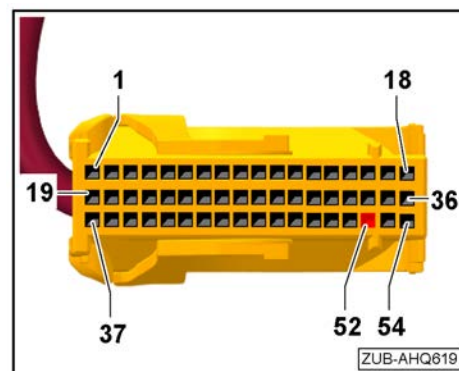

- Pin contacts 51 and 52 from connector A into the loose black 2-pin contact housing.

Pin 1 - from pin 52: CAN bus High, green

Pin 2 - from pin 51: CAN bus Low, orange/brown

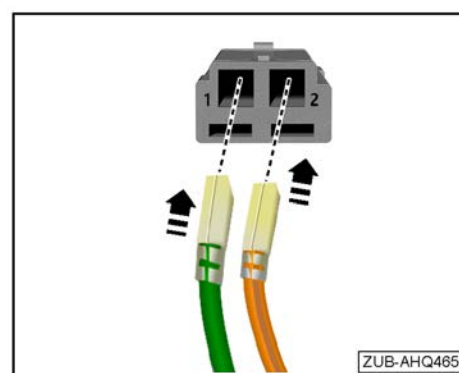

- Connect the black 2-pin contact housing that was just pinned -1- to the black 2-pin connector housing -2- on the retrofit harness.
- Secure using a cable tie to prevent noise.
- Connect and fasten connector A on the comfort system central control module -J393-.

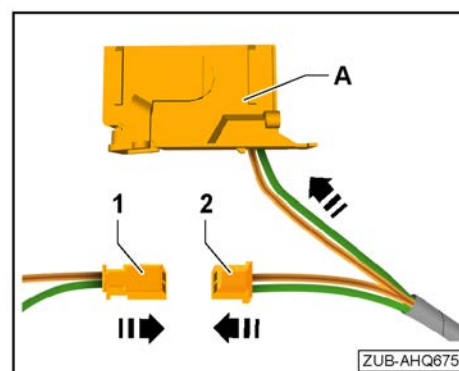

8.5 Inserting the fuses into the relay and fuse panel

- Insert the fuses into the relay and fuse panel -1-.

Fuse location F04 (2) - Fuse: 25 A

Fuse location F10 (3) - Fuse: 25 A

Fuse location F27 (4) - Fuse: 20 A

Fuse location F41 (5) - Mini-fuse: 15 A

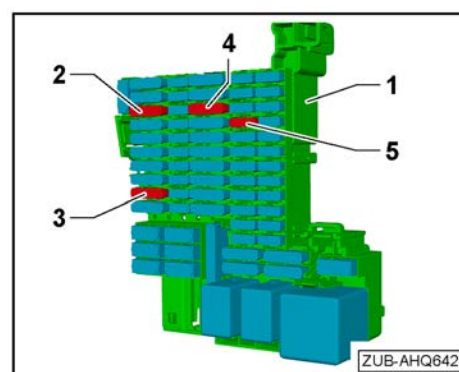



8.6 Connecting the Supply Line for the Brake Booster

- The vehicle electrical system's supply wire for the brake booster -1- is secured to the main wiring harness ex works.
- Connect the onboard supply wire for the brake booster -1- to the wire for the brake booster of the socket retrofit wiring harness -2- -in the direction of the arrow-.

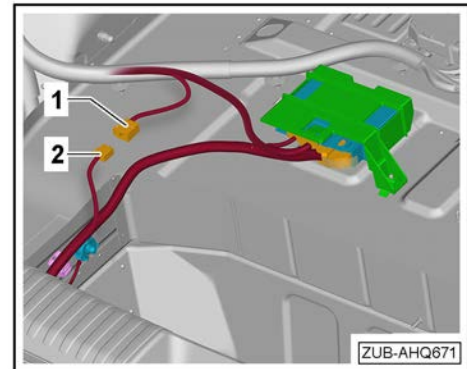

8.7 Connecting the CAN Bus

Note

- ◆ *The CAN bus is integrated by connecting the wires to the standard wiring harness on the left. The connector is connected at the standard wiring harness and secured using foam grommets to prevent noise from developing.*
- Connect the CAN bus connector -1-. Check for secure engagement
- Secure using a foam sleeve to prevent noise.

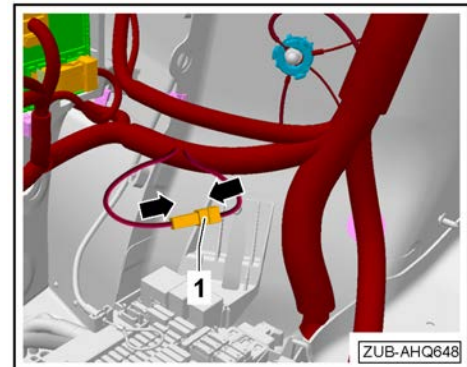



9 Final Tasks

9.1 Reassembling the Vehicle

To install the components, follow the removal steps in reverse order. Observe the “Notes on installation” for the relevant component and the corresponding tightening torques.

9.2 Connecting the Battery

- Connect the battery ⇒ Electrical system; Rep. Gr. 27; Battery; Disconnecting and connecting the battery

Note

After reconnecting the power supply, the ESP warning light can only extinguish after a few meters have been driven.

9.3 Adapting the towing recognition control module -J345- activation process

The activation process is carried out using the ⇒ vehicle diagnostic tester. This must be connected online.

NOTICE

Before you start the activation process, go into the self-diagnosis function and check that it is possible to contact the DA69 (trailer hitch control module); this ensures that the CAN bus is connected.

9.4 Functional Check on the Socket

- Check that the trailer socket is functioning correctly using a suitable trailer socket tester or a trailer.

Pin assignment at the trailer socket

- 1 - Terminal LH (left-hand brake light/turn signal)
- 2 - Terminal 31 (earth)
- 3 - Electrical brake (brake booster)
- 4 - Terminal RH (right-hand brake light/turn signal)
- 5 - Terminal 30 (battery +)

NOTICE

Constant current 12 V, max. current 15 A.

- 6 - Terminal 58 (tail lamps)
- 7 - Terminal RVL (reversing light)

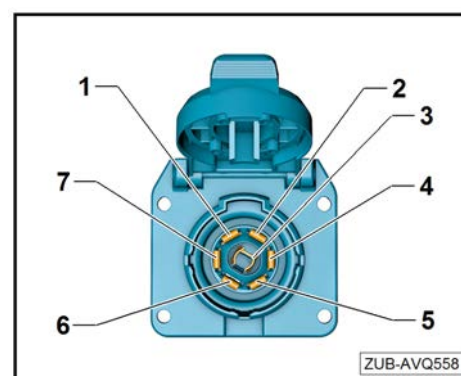



9.5 Reassembling the Vehicle

To install the components, follow the removal steps in reverse order. Observe the “Notes on installation” for the relevant component and the corresponding tightening torques.

On vehicles with lane change assistance, this must be recalibrated.

NOTICE

The following information must be observed when working with the lane change assist (Audi side assist):

- ◆ **If the rear bumper cover is removed and then reinstalled, or if any modifications are made to the rear bumper cover, the lane change assist system (Audi side assist) must be recalibrated ⇒ Electrical system; Rep. Gr. 96; Risk of accident due to malfunction!**